

5504-MIDI-MIC Firmware

Signal Processing Synoptic

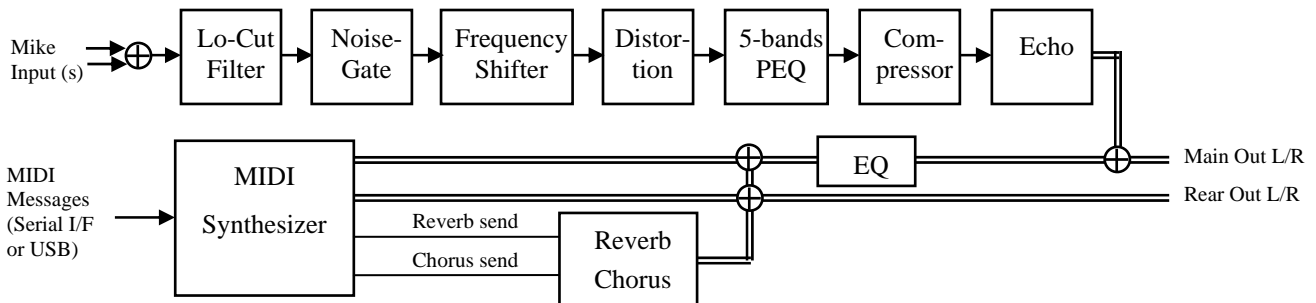

Features of MIDI Synthesizer

- minimum hardware configuration : SAM5504 + QSPI-NOR-Flash + stereo DAC
- 48KHz or 44.1KHz sampling rate (12.288MHz or 11.2896MHz quartz)
- Full GM/™ implementation
- up to 54 voice polyphony (with all Effects and Microphone Input processing enabled)
- 32 MIDI channels
- ™ compatible Reverb, Chorus
- Equalizer on Main L/R outputs

Available Sound Bank: CleanWave128® (128Mbit, 128 GM instruments + 140 variations, 9 drumsets), others on request.

Features of Mike Inputs processing

- 2 Microphone inputs with individual Gain control,
- Low-Cut Filter, Noise Gate
- Feedback reduction with Frequency Shifter
- Distortion, for effects like Tube-Overdrive, Megaphone etc.
- Tone control: 5 bands Parametric Equalizer (+/- 15dB)
- Compressor / Limiter
- Echo with up to 600ms time, mono or stereo (ping-pong) types

Available Reference Designs: 5504-EK or 5504-DK (stand-alone evaluation / development board)

Mike inputs and “Rear” Audio outputs only available on 5504-DK board.



Roland, the GS logo are trademarks of Roland Corporation.
Other cited trademarks belong to their respective owners
General MIDI logo under license of MIDI Manufacturers Association

This publication neither states nor implies any warranty of any kind, including, but not limited to, implied warrants of merchantability or fitness for a particular application. Dream assumes no responsibility for the use of any circuitry. No circuit patent licenses are implied.
The information in this publication is believed to be accurate in all respects at the time of publication but is subject to change without notice. Dream assumes no responsibility for errors and omissions, and disclaims responsibility for any consequences resulting from the information included herein.

Contact: info@dream.fr

DREAM Special NRPN Controls

NRPN sending method:

CTRL#99=high byte (MSB), CTRL#98=low byte (LSB), CTRL#6=value (MSB), CTRL#38=value (LSB for 14bit value)

Example:

In order to set MIDI Synthesizer Master Volume (NRPN 3707h) to value 64 (40h), send

- CTRL#99=56 (37h) (MIDI code: 0B0h 063h 037h)
- CTRL#98=07 (07h) (MIDI code: 0B0h 062h 007h)
- CTRL#6 =64 (40h) (MIDI code: 0B0h 006h 040h)

MIDI channel must be 0 for all these NRPNs.

NRPN # MSB LSB	Description	Power-up default
3707h	Synth Master Volume 0 (mute) to 7Fh (max)	7Fh
3755h	Synth Equalizer ON/OFF 0=OFF, else ON	ON
3708h	Synth Equalizer Low Band Gain 0=-12dB, 40h=0dB, 7Fh=+12dB	60h (+6dB)
370Bh	Synth Equalizer High Band Gain 0=-12dB, 40h=0dB, 7Fh=+12dB	60h (+6dB)
370Ch	Synth Equalizer Low Band Freq. 0=0Hz, 64=400Hz, 127=800Hz	0Ah (100Hz)
370Fh	Synth Equalizer High Band Freq. 0=1kHz, 64=3.4KHz, 127=5.8kHz	7Fh
3758h	Reverb Front output level (0 to 7Fh)	7Fh
3759h	Reverb Rear output level (0 to 7Fh)	0
375Ah	Chorus Front output level (0 to 7Fh)	7Fh
375Bh	Chorus Rear output level (0 to 7Fh)	0
375Eh	General Synth Output Front level (0 to 7Fh, 0=mute, ... 40h=0dB, ... 7Fh=+6dB)	60h (+3.5dB)
375Fh	General Synth Output Rear level (0 to 7Fh, 0=mute, ... 40h=0dB, ... 7Fh=+6dB)	60h (+3.5dB)
38xxh	Synth Front/Rear mix of MIDI channel xxh xxh=0 to 0Fh if port 1, xxh=10h to 1Fh if port 2 value = 0 to 7Fh: 0=all Front, 40h=center, 7Fh=all Rear	0
3751h	Auto-Test (see next page)	-
Microphone Input Controls		
0800h	Noise Gate Threshold level: 0 = off, 1..29h = -90dB, 2Ah=-85dB, 2Bh=84dB... 7Fh = 0dB	
0801h	Noise Gate Release: 0 = ~0.01s... 127 = ~10s	
0802h	Microphone Input 1 Level: 0=-Inf ... 74h = 0dB ... 7Dh = +9dB, 7Eh = +10dB, 7Fh = +11dB	74h (0dB)
0803h	Frequency Shifter ON/OFF: 0 = off, else ON	0 (OFF)
0804h	Frequency Shifter Amount: 0 = -8Hz .. 64 = 0Hz ... 127 = +8Hz	64
0805h	Frequency Shifter Post-HP: 0 = off, else HPF at 20Hz	0 (OFF)
0806h	Low-Cut Filter ON/OFF: 0 = off, else HPF at 50Hz	1 (ON)
080Ah	Microphone Input 2 Level: 0=-Inf ... 74h = 0dB ... 7Dh = +9dB, 7Eh = +10dB, 7Fh = +11dB	74h (0dB)
0810h	Direct L send: 0...127 = -oo...0dB	127
0811h	Direct R send: 0...127 = -oo...0dB	127
0812h	Reverb send: 0...127 = -oo...0dB	0
0813h	Chorus send: 0...127 = -oo...0dB	0
0814h	Echo send: 0...127 = -oo...0dB	32
0830h	Input Peak-Level request	-
Microphone Distortion Controls		
0D00h	Distortion ON/OFF: =0 OFF, else ON	OFF
0D02h	Drive Amount: 0 = linear 1 ... 20h: tube overdrive, >20h ... 7Fh: min ...max distortion	
0D03h	Hi-Cut Filter Frequency: 0...7Fh = ~1KHz...OFF	
0D04h	Hi-Cut Filter Resonance: 0 = no resonance ... 7Fh max resonance	
0D05h	Lo-Cut Filter Frequency: 0...7Fh = ~30Hz...~1KHz	
Microphone Compressor Controls		
0500h	Compressor ON/OFF: =0 OFF, else ON	OFF
0501h	Attack time: 0=fast attack (0.1ms), ... 60=1ms, ...100=10ms, till 127=slow attack (100ms), exp. Curve	
0502h	Release time: 0=fast release (10ms), ... 60=100ms, ... 100=1s, till 127=slow release (~5s), exp. Curve	
0503h	Threshold: 127=0dB, 64=-6dB, 32=-12dB, 16=-18dB, 8=-24dB, 4=-30dB, 2=-36dB 0=-Inf	
0504h	Ratio: 127=1/128, 126=2/128 (1/64), 125=3/128, ... 64=64/128 (1/2), ... 0=1/1	

0505h	Boost: 0 = 0dB, 0x20=+4.5dB,... 0x40=+9dB, ... 0x7F=+18dB	
057Fh	Compressor Preset (see Compressor Presets table)	0 (OFF)
Microphone Parametric Equalizer		
0900h... 0904h	EQ Band Gain: 31h = -15dB ... 40h = 0dB ... 4Fh = +15dB	
0910h... 0914h	EQ Band Frequency: 20..16000 (in Hz, using value send in 14bit, with LSB)	
0921h... 0923h	EQ Band Q (only for 3 mid bands): 0= 0.707, 1...127	
097Fh	PEQ Presets: 0=OFF, 1=default	
Microphone Echo Controls		
0200h	Echo Type: 0=OFF, 10=Mono-Echo, 11=Stereo-Echo	10
0201h	Pre-High-Pass Filter Frequency: 0=no Filter ... 127 = 1KHz	0
0202h	Pre-High-Shelf Filter Gain: 0 = -12dB ... 64 = 0dB ... 127=+12dB	64
0203h	Pre-High-Shelf Filter Frequency: 0 = 1KHz ... 127 = 5KHz	127
0204h	Long Echo Mode: 0=OFF, else Echo time 40...600ms	0
0205h	Echo Time: 0 = 20ms ... 127 = 300ms (see "Long Echo Mode")	127
0206h	Feedback: 0 = no feedback ... 127 = 100%	32
0207h	H-Damp Filter : 0 = no damping ..127 = max high frequency damping	0
0208h	L-Damp Filter : 0 = no damping ..127 = max low frequency damping	0
0209h	Echo Output Level left: 0 = muted ... 127 = max	127
020Ah	Echo Output Level right: 0 = muted ... 127 = max	127
020Bh	Echo Output Phase left: 0=normal, else inverted	0
020Ch	Echo Output Phase right: 0=normal, else inverted	0
027Fh	Echo Preset (see Echo Presets table)	1

Microphone Compressor/Limiter Presets

Nb	Name	Preset Default values				
		Attack	Release	Threshold	Ratio	Boost
0	OFF	/	/	/	/	/
COMPRESSOR						
1	COMPRESSOR 1: -18dB 2:1	64	0	73	64	24
2	COMPRESSOR 2: -15dB 3:1	64	0	82	84	32
3	COMPRESSOR 3: -18dB 5:1	64	0	73	100	48
4	COMPRESSOR 4: -21dB 7:1	64	0	64	110	48
5	COMPRESSOR 5: -24dB 12:1	64	0	55	117	64
LIMITER						
6	LIMITER 1: -6dB	0	64	109	127	0
7	LIMITER 2: -18dB	0	64	91	127	0
8	LIMITER 3: -12dB	0	64	73	127	8

Microphone Echo Presets

Nb	Name	Preset Default Values							
		Level	Delay Time	Feedback	H-Damp	L-Damp	Pre-HP	Tone-Gain	Tone-Freq.
0	OFF	/	/	/	/	/	/	/	/
1	Mono-Echo	90	121	26	64	64	16	70	77
2	Stereo-Echo	90	127	83	64	0	17	95	77

Auto-Test

Built-in auto-test program is included which can be used for board production testing. Sine waveforms at different frequencies will be output to the DAC to indicate test in progress. Last sine waveform is output constantly to allow test of audio outputs. Board must be reset to exit test mode and return in normal mode.

Detailed MIDI Implementation

2 ports of 16 channels are provided for a total of 32 channels. MIDI Message “F5 nn” is used to switch between the two ports (nn=1 or 2).

MIDI Message	HEX Code	Description	Compatibility
NOTE ON	9nH kk vv	Midi channel n(0-15) note ON #kk(1-127), velocity vv(1-127). vv=0 means NOTE OFF	MIDI
NOTE OFF	8nH kk vv	Midi channel n(0-15) note OFF #kk(1-127), vv is don't care.	MIDI
PITCH BEND	EnH bl bh	Pitch bend as specified by bh bl (14 bits) Maximum swing is +/- 1 tone (power-up). Can be changed using « pitch bend sensitivity ». Center position is 00H 40H.	GM
PROGRAM CHANGE	CnH pp	Program (patch) change. Specific action on channel 10 (n=9) : select drumset. Refer to sounds / drumset list. Drumsets can be assigned to other channels (see SYSEX MIDI channel to part assign and part to rhythm allocation)	GM/GS
CHANNEL AFTERTOUCH	DnH vv	vv pressure value. Effect set using Sys. Ex. 40H 2pH 20H-26H	MIDI
CTRL 00	BnH 00H cc	Bank select : Refer to sounds list. No action on drumset	GS/ DREAM
CTRL 01	BnH 01H cc	Modulation wheel. Rate and maximum depth can be set using SYSEX	MIDI
CTRL 05	BnH 05H cc	Portamento time.	MIDI
CTRL 06	BnH 06H cc	Data entry : provides data to RPN and NRPN	MIDI
CTRL 07	BnH 07H cc	Volume (default=100)	MIDI
CTRL 10	BnH 0AH cc	Pan (default=64 center)	MIDI
CTRL 11	BnH 0BH cc	Expression (default=127)	MIDI/GM
CTRL 64	BnH 40H cc	Sustain (damper) pedal	MIDI
CTRL 65	BnH 41H cc	Portamento ON/OFF	MIDI
CTRL 66	BnH 42H cc	Sostenuto pedal	MIDI
CTRL 67	BnH 43H cc	Soft pedal	MIDI
CTRL 71	BnH 47H cc	TVF Resonance modify (same as nrpn 0121h)	GM/GS
CTRL 72	BnH 48H cc	Env release time modify (same as nrpn 0166h)	GM/GS
CTRL 73	BnH 49H cc	Env attack time modify (same as nrpn 0163h)	GM/GS
CTRL 74	BnH 4AH cc	TVF cutoff freq modify (same as nrpn 0120h)	GM/GS
CTRL 75	BnH 4BH cc	Env decay time modify (same as nrpn 0164h)	GM/GS
CTRL 76	BnH 4CH cc	Vibrato rate modify (same as nrpn 0108h)	GM/GS
CTRL 77	BnH 4DH cc	Vibrato depth modify (same as nrpn 0109h)	GM/GS
CTRL 78	BnH 4EH cc	Vibrato delay modify (same as nrpn 010Ah)	GM/GS
CTRL 84	BnH 54H vv	Portamento control	GS
CTRL 91	BnH 5BH vv	Reverb send level vv=00H to 7FH	GS
CTRL 93	BnH 5DH vv	Chorus send level vv=00H to 7FH	GS
CTRL 98	BnH 62H vv	NRPN low	MIDI
CTRL 99	BnH 63H vv	NRPN high	MIDI
CTRL 100	BnH 64H vv	RPN low	MIDI
CTRL 101	BnH 65H vv	RPN high	MIDI
CTRL 120	BnH 78H 00H	All sound off (abrupt stop of sound on channel n)	MIDI
CTRL 121	BnH 79H 00H	Reset all controllers	MIDI
CTRL 123	BnH 7BH 00H	All notes off	MIDI
CTRL 126	BnH 7EH 00H	Mono on	MIDI
CTRL 127	BnH 7FH 00H	Poly on (default power-up)	MIDI

CTRL CC1	BnH ccH vvH	Assignable Controller 1. cc=Controller number (0-5Fh), vv=Control value (0-7Fh). Control number (ccH) can be set on CC1 CONTROLLER NUMBER (Sys. Ex 40 1x 1F). The resulting effect is determined by CC1 controller function (Sys.Ex. 40 2p 40-4A)	GS
CTRL CC2	BnH ccH vvH	Assignable Controller 2. cc=Controller number (00h-5Fh), vv=control value (0-7Fh). Control number can be set on CC2 CONTROLLER NUMBER (Sys.Ex. 40 1x 20). The resulting effect is determined by CC2 controller function (Sys.Ex.40 2p 50-5A).	GS
RPN 0000H	BnH 65H 00H 64H 00H 06H vv	Pitch bend sensitivity in semitones (default=2)	MIDI/GM
RPN 0001H	BnH 65H 00H 64H 01H 06H vv	Fine tuning in cents (vv=00 -100, vv=40H 0, vv=7FH +100)	MIDI
RPN 0002H	BnH 65H 00H 64H 02H 06H vv	Coarse tuning in half-tones (vv=00 -64, vv=40H 0, vv=7FH +64)	MIDI
NRPN 0108H	BnH 63H 01H 62H 08H 06H vv	Vibrate rate modify (vv=40H -> no modif)	GS
NRPN 0109H	BnH 63H 01H 62H 09H 06H vv	Vibrate depth modify (vv=40H -> no modif)	GS
NRPN 010AH	BnN 63H 01H 62H 0AH 06H vv	Vibrate delay modify (vv=40H -> no modif)	GS
NRPN 0120H	Bnh 63H 01H 62H 20H 06H vv	TVF cutoff freq modify(vv=40H -> no modif)	GS
NRPN 0121H	BnH 63H 01H 62H 21H 06H vv	TVF resonance modify (vv=40H -> no modif)	GS
NRPN 0163H	Bnh 63H 01H 62H 63H 06H vv	Env. attack time modify(vv=40H ->no modif)	GS
NRPN 0164H	BnH 63H 01H 62H 64H 06H vv	Env. decay time modify(vv=40H -> no modif)	GS
NRPN 0166H	BnH 63H 01H 62H 66H 06H vv	Env. release time modif(vv=40H ->no modif)	GS
NRPN 18rrH	BnH 63H 18H 62H rr 06H vv	Pitch coarse of drum instr. note rr in semitones (vv=40H -> no modif) (note 6)	GS
NRPN 1ArrH	BnH 63H 1AH 62H rr 06H vv	Level of drum instrument note rr (vv=00 to 7FH) (note 6)	GS
NRPN 1CrrH	BnH 63H 1CH 62H rr 06H vv	Pan of drum instrument note rr (40H = middle) (note 6)	GS
NRPN 1DrrH	BnH 63H 1DH 62H rr 06H vv	Reverb send level of drum instrument note rr (vv=00 to 7FH) (note 6)	GS
NRPN 1ErrH	BnH 63H 1EH 62H rr 06H vv	Chorus send level of drum instrument note rr (vv=00 to 7FH) (note 6)	GS
NRPN 37nnH	BnH 63H 37H 62H nn 06H vv	DREAM Special NRPN Controls (see page 2)	DREAM
Standard Sysex	FOH 7EH 7FH 09H 01H F7H	General MIDI reset (note 4)	GM
Standard Sysex	FOH 7FH 7FH 04H 01H 00H 11 F7H	Master volume (11=0 to 127, default 127) (note 4). Not reset by GS reset	GM
SYSEX	FOH 41H 00H 42H 12H 40H 00H 00H dd dd dd dd xx F7H	Master tune (default dd= 00H 04H 00H 00H) -100.0 to +100.0 cents. Nibblized data should be used (always four bytes). For example, to tune to +100.0 cents, sent data should be 00H 07H 0EH 08H (note 4)	GS
SYSEX	FOH 41H 00H 42H 12H 40H 00H 04H vv xx F7H	Master volume (default vv=7FH) (note 4) Not reset by GS reset.	GS
SYSEX	FOH 41H 00H 42H 12H 40H 00H 05H vv xx F7H	Master key-shift (default vv=40H, no transpose) (note 4)	GS
SYSEX	FOH 41H 00H 42H 12H 40H 00H 06H vv xx F7H	Master pan (default vv=40H, center) (note 4)	
SYSEX	FOH 41H 00H 42H 12H 40H 00H 7FH 00H xx F7H	GS reset (note 4)	GS
SYSEX	FOH 41H 00H 42H 12H 40 01H 10H vv1 vv2 vv3 vv4 vv5 vv6 vv7 vv8 vv9 vv10 vv11 vv12 vv13 vv14 vv15 vv16 xx F7h	Voice reserve : vv1= Part 10 (Default vv=2) vv2 to vv10 = Part 1 to 9 (Default vv=2) vv11 to vv16= Part 11 to 16 (Default vv=0) (note 4)	GS

SYSEX	F0H 41H 00H 42H 12H 40H 01H 30H vv xx F7H	Reverb type (vv=0 to 7), default = 04H 00H : Room1 01H : Room2 02H : Room3 03H : Hall1 04H : Hall2 05H : Plate 06H : Delay 07H : Pan delay (note 5)	GS
SYSEX	F0H 41H 00H 42H 12H 40H 01H 31H vv xx F7H	Reverb character, default 04H (note 5)	GS
SYSEX	F0H 41H 00H 42H 12H 40H 01H 32H vv xx F7H	Reverb Pre-LPF, 0 to 7, default 0 (note 5)	GS
SYSEX	F0H 41H 00H 42H 12H 40H 01H 33H vv xx F7H	Reverb master level, default = 64 (note 5)	GS
SYSEX	F0H 41H 00H 42H 12H 40H 01H 34H vv xx F7H	Reverb time (note 5)	GS
SYSEX	F0H 41H 00H 42H 12H 40H 01H 35H vv xx F7H	Reverb delay feedback. Only if reverb number=6 or 7 (delays) (note 5)	GS
SYSEX	F0H 41H 00H 42H 12H 40H 01H 37H vv xx F7H	Reverb pre delay time (vv=0 to 7Fh = 0ms to 127ms). Only if reverb number=0 to 5 (reverbs)	GS
SYSEX	F0H 41H 00H 42H 12H 40H 01H 38H vv xx F7H	Chorus type (vv=0 to 7), default = 02H 00H : Chorus1 01H : Chorus2 02H : Chorus3 03H : Chorus4 04H : Feedback 05H : Flanger 06H : Short delay 07H : FB delay (note 5)	GS
SYSEX	F0H 41H 00H 42H 12H 40H 01H 39H vv xx F7H	Chorus Pre-LPF, 0 to 7, default = 0 (note 5)	GS
SYSEX	F0H 41H 00H 42H 12H 40H 01H 3AH vv xx F7H	Chorus master level, default = 64 (note 5)	GS
SYSEX	F0H 41H 00H 42H 12H 40H 01H 3BH vv xx F7H	Chorus feedback (note 5)	GS
SYSEX	F0H 41H 00H 42H 12H 40H 01H 3CH vv xx F7H	Chorus delay (note 5)	GS
SYSEX	F0H 41H 00H 42H 12H 40H 01H 3DH vv xx F7H	Chorus rate (note 5)	GS
SYSEX	F0H 41H 00H 42H 12H 40H 01H 3EH vv xx F7H	Chorus depth (note 5)	GS
SYSEX	F0H 41H 00H 42H 12H 40H 01H 3FH vv xx F7H	Chorus send level to reverb, default=0 (note 5)	GS
SYSEX	F0H 41H 00H 42H 12H 40H 02H 00H vv xx F7H	EQ Low Freq, vv: 0=200Hz, 1=400Hz, default 0	GS
SYSEX	F0H 41H 00H 42H 12H 40H 02H 01H vv xx F7H	EQ Low Gain, vv: 0=-12dB, 40h=0dB, to7Fh=+12dB, default 60h=+6dB	GS
SYSEX	F0H 41H 00H 42H 12H 40H 02H 02H vv xx F7H	EQ High Freq, vv: 0=3KHz, 1=6KHz, default 0	GS
SYSEX	F0H 41H 00H 42H 12H 40H 02H 03H vv xx F7H	EQ High Gain, vv: 0=-12dB, 40h=0dB, to7Fh=+12dB, default 60h=+6dB	GS
SYSEX	F0H 41H 00H 42H 12H 40H 1pH 02H nn xx F7H	MIDI channel to part assign, p is part (0 to 15), nn is MIDI channel (0 to 15, 16=OFF). This SYSEX allows to assign several parts to a single MIDI channel or to mute a part. (note 3) Default assignment : <u>part</u> <u>MIDI channel</u> 0 9 (DRUMS) 1-9 0-8 10-15 10-15	GS

SYSEX	F0H 41H 00H 42H 12H 40H 1pH 15H vv xx F7H	Part to rhythm allocation, p is part (0 to 15), vv is 00 (sound part) or 01 (rhythm part). This SYSEX allows a part to play sound or drumset. There is no limitation of the number of parts playing drumset. Default assignment : part 0 plays drums (default MIDI channel 9) all other parts play sound. (note 3)	GS
SYSEX	F0H 41H 00H 42H 12H 40H 1pH 40H v1 v2 ... v12 xx F7H	Scale tuning, p is part (0 to 15), v1 to v12 are 12 semi-tones tuning values (C, C#, D, ... A#, B), in the range -64 (00H) 0 (40H) +63(7FH) cents. This SYSEX allows non chromatic tuning of the musical scale on a given part. Default v1, v2, ... ,v12 = 40H, 40H,...,40H (chromatic tuning). Scale tuning has no effect if the part is assigned to a rhythm channel or if the sound played is not of chromatic type. (note 3)	GS
SYSEX	F0H 41H 00H 42H 12H 40H 1pH 1AH vv xx F7H	Velocity slope from 00H to 7FH (default = 40H) (note 3)	GS
SYSEX	F0H 41H 00H 42H 12H 40H 1pH 1BH vv xx F7H	Velocity offset from 00H to 7FH (default = 40H) (note 3)	GS
SYSEX	F0H 41H 00H 42H 12H 40H 1pH 1FH vv xx F7H	CC1 Controller number (00-5FH) (default = 10H) (note 3)	GS
SYSEX	F0H 41H 00H 42H 12H 40H 1pH 20H vv xx F7H	CC2 Controller number (00-5FH) (default = 11H) (note 3)	GS
SYSEX	F0H 41H 00H 42H 12H 40H 2pH 00H vv xx F7H	Mod pitch control (-24,+24 semitone) (default = 40H) (note 3)	GS
SYSEX	F0H 41H 00H 42H 12H 40H 2pH 01H vv xx F7H	Mod tvf cutoff control (default = 40H) (note 3)	GS
SYSEX	F0H 41H 00H 42H 12H 40H 2pH 02H vv xx F7H	Mod Amplitude control (-100%--+100%) (default=40H) (note 3)	GS
SYSEX	F0H 41H 00H 42H 12H 40H 2pH 03H vv xx F7H	Mod lfo1 rate control (default = 40H). n is don't care. Rate is common on all channels	GS
SYSEX	F0H 41H 00H 42H 12H 40H 2pH 04H vv xx F7H	Mod lfo1 pitch depth (0-600 cents) (default=0AH) (note 3)	GS
SYSEX	F0H 41H 00H 42H 12H 40H 2pH 05H vv xx F7H	Mod lfo1 tvf depth (default = 0H) (note 3)	GS
SYSEX	F0H 41H 00H 42H 12H 40H 2pH 06H vv xx F7H	Mod lfo1 tva depth (0-100%) (default = 0H) (note 3)	GS
SYSEX	F0H 41H 00H 42H 12H 40H 2pH 10H vv xx F7H	Bend pitch control (-24,+24 semitone) (default = 42H) (note 3)	GS
SYSEX	F0H 41H 00H 42H 12H 40H 2pH 11H vv xx F7H	Bend tvf cutoff control (default = 40H) (note 3)	GS
SYSEX	F0H 41H 00H 42H 12H 40H 2pH 12H vv xx F7H	Bend Amplitude control (-100%--+100%) (default=40H) (note 3)	GS
SYSEX	F0H 41H 00H 42H 12H 40H 2pH 14H vv xx F7H	Bend lfo1 pitch depth (0-600 cents) (default=00H) (note 3)	GS
SYSEX	F0H 41H 00H 42H 12H 40H 2pH 15H vv xx F7H	Bend lfo1 tvf depth (default = 0H) (note 3)	GS
SYSEX	F0H 41H 00H 42H 12H 40H 2pH 16H vv xx F7H	Bend lfo1 tva depth (0-100%) (default = 0H) (note 3)	GS
SYSEX	F0H 41H 00H 42H 12H 40H 2pH 20H vv xx F7H	CAF pitch control (-24,+24 semitone) (default = 40H) (note 3)	GS
SYSEX	F0H 41H 00H 42H 12H 40H 2pH 21H vv xx F7H	CAF tvf cutoff control (default = 40H) (note 3)	GS
SYSEX	F0H 41H 00H 42H 12H 40H 2pH 22H vv xx F7H	CAF Amplitude control (-100%--+100%) (default=40H) (note 3)	GS

SYSEX	F0H 41H 00H 42H 12H 40H 2pH 24H vv xx F7H	CAF lfo1 pitch depth (0-600 cents) (default=00H) (note 3)	GS
SYSEX	F0H 41H 00H 42H 12H 40H 2pH 25H vv xx F7H	CAF lfo1 tvf depth (default = 0H) (note 3)	GS
SYSEX	F0H 41H 00H 42H 12H 40H 2pH 26H vv xx F7H	CAF lfo1 tva depth (0-100%) (default = 0H) (note 3)	GS
SYSEX	F0H 41H 00H 42H 12H 40H 2pH 40H vv xx F7H	CC1 pitch control (-24,+24 semitone) (default = 40H) (note 3)	GS
SYSEX	F0H 41H 00H 42H 12H 40H 2pH 41H vv xx F7H	CC1 tvf cutoff control (default = 40H) (note 3)	GS
SYSEX	F0H 41H 00H 42H 12H 40H 2pH 42H vv xx F7H	CC1 Amplitude control (-100%+100%) (default=40H) (note 3)	GS
SYSEX	F0H 41H 00H 42H 12H 40H 2pH 44H vv xx F7H	CC1 lfo1 pitch depth (0-600 cents) (default=00H) (note 3)	GS
SYSEX	F0H 41H 00H 42H 12H 40H 2pH 45H vv xx F7H	CC1 lfo1 tvf depth (default = 0H) (note 3)	GS
SYSEX	F0H 41H 00H 42H 12H 40H 2pH 46H vv xx F7H	CC1 lfo1 tva depth (0-100%) (default = 0H) (note 3)	GS
SYSEX	F0H 41H 00H 42H 12H 40H 2pH 50H vv xx F7H	CC2 pitch control (-24,+24 semitone) (default = 40H) (note 3)	GS
SYSEX	F0H 41H 00H 42H 12H 40H 2pH 51H vv xx F7H	CC2 tvf cutoff control (default = 40H) (note 3)	GS
SYSEX	F0H 41H 00H 42H 12H 40H 2pH 52H vv xx F7H	CC2 Amplitude control (-100%+100%) (default=40H) (note 3)	GS
SYSEX	F0H 41H 00H 42H 12H 40H 2pH 54H vv xx F7H	CC2 lfo1 pitch depth (0-600 cents) (default=00H) (note 3)	GS
SYSEX	F0H 41H 00H 42H 12H 40H 2pH 55H vv xx F7H	CC2 lfo1 tvf depth (default = 0H) (note 3)	GS
SYSEX	F0H 41H 00H 42H 12H 40H 2pH 56H vv xx F7H	CC2 lfo1 tva depth (0-100%) (default = 0H) (note 3)	GS
SYSEX	F0H 41H 00H 42H 12H 40H 4pH 22H nn xx F7H	with 'p'=MIDI track, 'nn': 0 = track in normal mode, 1 = send to MFX1, 2 = send to MFX2, 3 = send to both MFX	GS / DREAM

- Notes :**
- NRPN sending method : CTRL#99=high byte, CTRL#98=low byte, CTRL#6=vv. Example : NRPN 0108h = 40h -> CTRL#99=1, CTRL#98=8, CTRL#6=64.
 - x or xx means « don't care »
 - Cross system exclusive :
Address can be 040h xxh xxh or 050h xxh xxh
If adresse=040h xxh xxh : system exclusive applies to midi port 1 (midi channels 0-Fh) if received on midi port1 , applies to midi port 2 (midi channels 10-1Fh) if received on midi port 2.
If adresse=050h xxh xxh, cross system exclusive : applies to port 2 if received on port1, applies to port 1 if received on port2
 - Non cross system exclusive applying only on receiving port :
System exclusive applies to midi port 1 (midi channels 0-Fh) if received on midi port1.
System exclusive applied to midi port 2 (midi channels 10-1Fh) if received on midi port2.
 - Non cross system exclusive applying on both ports :
System exclusive will be applied to all midi channels (0-1Fh). Can be received on port 1 or port 2 indifferently.
This is the case for all system exclusive concerning reverb and chorus because reverb and chorus are the same for both ports 1 and 2.
 - Drumset edit Nrpn : 4 different drumset edit tables are implemented :
 - 1 for midi port 1 channel 10
 - 1 for midi port 2 channel 10
 - 1 for midi port 1 channels 1-9 or 11-16 : for all these channels, edit table is the same
 - 1 for midi port 2 channels 1-9 or 11-16 : for all these channels, edit table is the same