

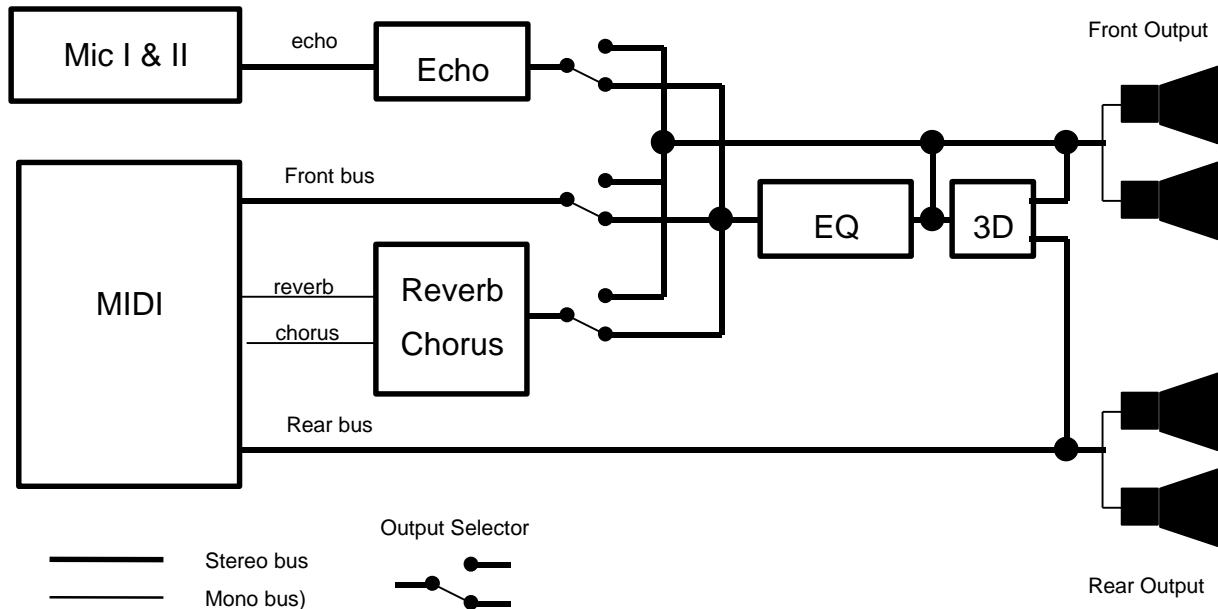

Signal Processing Synoptic



Features

- Minimum hardware configuration : SAM2634 + Flash + stereo DAC (I2S)
- 44.1Khz sampling rate (11.2896Mhz quartz)
- Full GM/  implementation
- 32 Midi channels
- Midi output on 4 audio channels
- Built-in  compatible reverb and chorus
- Built-in parametric equalizer, fully controllable by MIDI (1, 2 or 4 bands)
- Built-in Spatial Effect on 4 audio channels with MIDI control
- Microphone echo processing
- Microphone key and level detect for scoring
- Microphone pitch shift (doubler and funny effect)
- Software configurable for best polyphony/feature tradeoff
- Up to 64 voice polyphony if no effect selected



Roland, the GS logo are trademarks of Roland Corporation.
 Other cited trademarks belong to their respective owners
 General MIDI logo under license of MIDI Manufacturers Association
 © 2006-2014 DREAM S.A.S. France - All rights reserved

Doc Revision : March 2014

1- CONFIGURATION

1.1: Midi Baud rate

MIDI IN and OUT baud rate can be hardware selected through pin P3 of SAM2634.

If pin P3 is LOW, baud rate is standard midi baud rate: 31.25Kbit/s.

If pin P3 is HIGH baud rate is 200Kbit/s or 38.4Kbit/s. If USB-DBG-IF is connected in USB-MIDI mode on MIDI serial port, then the baud rate will be 200Kbit/s. Otherwise the baud rate will be 38.4Kbit/s.

The baud rate selection is done at start-up only.

1.2: Nrpn 03754H: DAC select

Midi message code (in hexadecimal) : B0H 63h 37h, B0H 62h 54h, B0H 06h vv

vv=42h if codec Crystal type (CS4216, CS4218)

vv=0Dh if Sony format type DAC, 16 bits (TDA1545)

vv=0Ch if IIS format type DAC (AK4352, CS4344)

vv=0Ch if IIS format type ADC/DAC (AK4528, CS4270)

Default is I2S DAC (vv=0Ch)

1.3: Nrpn 03755H: Effects on/off

Midi message code (in hexadecimal) : B0H 63h 37h, B0H 62h 55h, B0H 06h vv

Each bit of vv byte is used for selecting an effect ON or OFF as following:

7	6	5	4	3	2	1	0
0	0	REV	CHR	OM2	OM1	EQ2	EQ1

Each time an effect is ON polyphony will be decreased.

REV bit=1: Reverb ON, polyphony decreased by 13 (Default=1)

CHR bit=1: Chorus ON, polyphony decreased by 3 (Default=1)

OM2, OM1 bits: output mode select (Default is OM2=1, OM1=0) :

- OM2=0, OM1=0: 4 speaker mode OFF, Spatial Effect OFF

- OM2=1, OM1=0: Spatial Effect ON, polyphony decreased by 2. Spatial Effect parameters can be controlled using nrpn 3720h (volume), 372Ch (delay time), 372Dh (stereo/mono) and 372Eh (2/4 speaker mode) (see paragraph 2)

- OM2=1, OM1=1: 4 speaker midi output, polyphony decreased by 2. Each midi channel can be output to front or rear speakers using nrpn 3800h till 381Fh:

nrpn 38xxh = 0h: midi channel xxh is front speaker output

nrpn 38xxh = 7Fh: midi channel xxh is rear speaker output

Nrpn 3820h assigns all midi channels of first port (midi channels 0 to Fh). Nrpn 3821h assigns all midi channels of second port (midi channels 10h to 1Fh):

nrpn 3820h (3821h) = 0h : all midi channels of first (second) port are front speaker output

nrpn 3820h (3821h) =07Fh : all midi channels of first (second) port are rear speaker output

EQ2, EQ1 bits : Equalizer

- EQ2=0, EQ1=0 : equalizer off

- EQ2=0, EQ1=1 : 1 band equalizer (Low) , polyphony decreased by 2

- EQ2=1, EQ1=0 : 2 band equalizer (Low+High), polyphony decreased by 4 (Default)

- EQ2=1, EQ1=1 : 4 band equalizer (Low + Medium 1 + Medium 2 +High), polyphony decreased by 8

- If Equalizer and Spatial Effect are OFF, Nrpn 3718H, 3719H, 371AH must be always=0, otherwise no sound will be output.

- Default power-on values are: Rev=1, Chr=1 (Reverb/Chorus ON)
OM2=0, OM1=0 (Spatial Effect OFF)
EQ2=1, EQ1=0 (2 Band Equalizer)

1.4 Nrpn 03756H : Audio In functions on/off

Midi message code (in hexadecimal) : B0H 63h 37h, B0H 62h 56h, B0H 06h vv

Each bit of vv byte is used for selecting an Audio In function ON or OFF as following:

7	6	5	4	3	2	1	0
0	0	0	0	SCO	0	ECH	MIC

MIC bit=1: Mike1, Mike2 microphones ON, polyphony decreased by 1 (Default=0, Off)

ECH bit=1: Stereo echo on microphones ON, polyphony decreased by 2 (Default=0, Off)

SCO bit=1: Mike 1 key and level detect for scoring function, polyphony decreased by 5 (Default=0, Off) (see appendix 3)

1.5: Polyphony computation chart

The following chart allows to compute available polyphony as a function of mounted features. The available polyphony is 64 minus the polyphony requested by the mounted features.

Feature	Required polyphony	Power-up default
Reverb	13 (+1)	Mounted (13) (note 1)
Chorus	3 (+1)	Mounted (3) (note 1)
Spatial Effect	2	Not mounted
4 speaker MIDI output	2	Not mounted
Equalizer 4 (2, 1) bands	8 (4, 2)	Mounted 2 band (4)
Microphone	1	Not mounted
Microphone Echo	3	Not mounted
Microphone Scoring	5	Not mounted
Microphone 1 Pitch Shift	3	Not mounted
Microphone 2 Pitch Shift	3	Not mounted

Notes: -(1) The additional voice (+1) is common for reverb and chorus. Thus, if both chorus and reverb are ON, polyphony required for reverb and chorus is : 13+3+1=17 voices

-(2) Default is 64 - 17 (reverb/chorus) - 4 (Equalizer 2 band) = 43 voices

-(3) Spatial Effect and 4 speaker MIDI output are mutually exclusive

-(4) Some sounds require two voices

1.6: 32 Midi channels

2 ports of 16 midi channels are included in this firmware giving a total of 32 midi channels.

First midi port (channels 1 to 16) is selected if sending midi bytes 0F5h 01h.

Second midi port (channels 17 to 32) is selected if sending midi bytes 0F5h 02h (compatible with Roland midi driver).

For improving compatibility with Roland midi driver, midi baud rate can be changed from standard 31.25Kbit/s to 38.4Kbit/s (see paragraph 1.1).

2 SPECIAL MIDI CONTROLS

Nrpn # (High Low)	Description	Power-up default
3700H	Equalizer Low band (bass) 0=-12dB, 40H=0dB, 7FH=+12dB	60H
3701H	Equalizer Med Low band 0=-12dB, 40H=0dB, 7FH=+12dB	40H
3702H	Equalizer Med High band 0=-12dB, 40H=0dB, 7FH=+12dB	40H
3703H	Equalizer High band (treble) 0=-12dB, 40H=0dB, 7FH=+12dB	60H
3707H	Master Volume 0 to 7FH	7FH
3708H	Equalizer Low cutoff freq 0=0Hz to 7FH=3.4 kHz	0AH
3709H	Equalizer Med Low cutoff freq 0=0Hz to 7FH=3 kHz	17H
370AH	Equalizer Med High cutoff freq 0=0Hz to 7FH=3 kHz	61H
370BH	Equalizer High cutoff freq 0=0Hz to 7FH=13.7 kHz	40H
3713H	Clipping mode select 0=soft clip, 7FH=hard clip	00H
3715H	General Midi reverb send 0=no send,40H=default send,7FH=max	40H
3716H	General Midi chorus send 0=no send,40H=default send,7FH=max	40H
3718H	Post effects applied on GM 0= Post effects not applied (see note) 7Fh=Post effects applied	00H
3719H	Post effects applied on Mike 0= Post effects not applied (see note) 7Fh=Post effects applied	00H
371AH	Post effects applied on Reverb/Chorus 0= Post effects not applied (see note) 7Fh=Post effects applied	00H
3720H	Spatial Effect volume 0= no effect, 7FH= maximum effect	00H
3722H	General Midi volume 0 to 7FH	7FH
3723H	General Midi pan 0=left, 40H=center, 7FH=right	40H
3724H	Mike1 volume 0 to 7FH	40H
3725H	Mike2 volume 0 to 7FH	40H
3726H	Mike1 pan 0=hard left, 40H=center, 7FH=hard right	00H
3727H	Mike2 pan 0=hard left, 40H=center, 7FH=hard right	7FH
3728H	Mike Echo level 0 to 7FH	7FH
3729H	Mike Echo time 0=shortest to 7FH=longest	40H
372AH	Mike Echo feedback 0=no feedback to 7FH=maximum feedback	42H
372CH	Spatial Effect delay 0=shortest to 7Fh=longest (see appendix 1)	1DH
372DH	Spatial Effect input 0=stereo 7Fh=mono (see appendix 1)	00H
372EH	Spatial Effect output mode 0=front speakers, 7Fh=rear speakers (see appendix 1)	00H
3730H	Slave1 Echo volume right 0 to 7FH (see appendix 2)	54H
3731H	Slave1 Echo volume left 0 to 7FH (see appendix 2)	7FH
3732H	Slave2 Echo volume right 0 to 7FH (see appendix 2)	7FH
3733H	Slave2 Echo volume left 0 to 7FH (see appendix 2)	54H
3734H	Master Echo volume right 0 to 7FH (see appendix 2)	6CH
3735H	Master Echo volume left 0 to 7FH (see appendix 2)	6CH
373CH	Mike 1 Pitch Shift 0 to 0Fh (see appendix 4)	00H
373DH	Mike 2 Pitch Shift 0 to 0Fh (see appendix 4)	00H
3741H	Mike 1 key detect latency 1 to 7Fh (see appendix 3)	18H
3751H	Auto - test See paragraph 5 below	
3754H	DAC select See paragraph 1-2 above	0CH
3755H	Effects on/off See paragraph 1-3 above	32H
3756H	Audio In functions on/off See paragraph 1-4 above	00H
3757H	System Exclusive Devide ID 0 to 1Fh, 20h=all accepted	20H

Note: Post effects are Spatial Effect + Equalizer. This Nrpn must be 0 (post effect not applied) if both Spatial Effect and Equalizer are unselected using Nrpn 3755H (see paragraph 1.3).

3- DETAILED MIDI IMPLEMENTATION

MIDI MESSAGE	HEX CODE	DESCRIPTION
NOTE ON	9nH kk vv	Midi channel n(0-15) note ON #kk(1-127), velocity vv(1-127). vv=0 means NOTE OFF
NOTE OFF	8nH kk vv	Midi channel n(0-15) note OFF #kk(1-127), vv is don't care.
PITCH BEND	EnH bl bh	Pitch bend as specified by bh bl (14 bits) Maximum swing is +/- 1 tone (power-up). Can be changed using "pitch bend sensitivity". Center position is 00H 40H.
PROGRAM CHANGE	CnH pp	Program (patch) change. Specific action on channel 10 (n=9) : select drumset. Refer to sounds / drumset list. Drumsets can be assigned to other channels (see SYSEX MIDI channel to part assign and part to rhythm allocation)
CHANNEL AFTERTOUCH	DnH vv	vv pressure value. Effect set using Sys. Ex. 40H 2nH 20H-26H
MIDI RESET	FFH	Reset to power-up condition
CTRL 00	BnH 00H cc	Bank select : Refer to sounds list. No action on drumset. cc=64 reserved for dream sound editor
CTRL 01	BnH 01H cc	Modulation wheel. Rate and maximum depth can be set using SYSEX
CTRL 05	BnH 05H cc	Portamento time.
CTRL 06	BnH 06H cc	Data entry : provides data to RPN and NRPN
CTRL 07	BnH 07H cc	Volume (default=100)
CTRL 10	BnH 0AH cc	Pan (default=64 center)
CTRL 11	BnH 0BH cc	Expression (default=127)
CTRL 64	BnH 40H cc	Sustain (damper) pedal
CTRL 65	BnH 41H cc	Portamento ON/OFF
CTRL 66	BnH 42H cc	Sostenuto pedal
CTRL 67	BnH 43H cc	Soft pedal
CTRL 71	BnH 47H cc	TVF Resonance modify (same as nrpn 0121h)
CTRL 72	BnH 48H cc	Env release time modify (same as nrpn 0166h)
CTRL 73	BnH 49H cc	Env attack time modify (same as nrpn 0163h)
CTRL 74	BnH 4AH cc	TVF cutoff freq modify (same as nrpn 0120h)
CTRL 75	BnH 4BH cc	Env decay time modify (same as nrpn 0164h)
CTRL 76	BnH 4CH cc	Vibrato rate modify (same as nrpn 0108h)
CTRL 77	BnH 4DH cc	Vibrato depth modify (same as nrpn 0109h)
CTRL 78	BnH 4EH cc	Vibrato delay modify (same as nrpn 010Ah)
CTRL 80	BnH 50H vv	Reverb program vv=00H to 07H (default 04H) 00H: Room1 01H: Room2 02H: Room3 03H: Hall1 04H: Hall2 05H: Plate 06H: Delay 07H: Pan delay
CTRL 81	BnH 51H vv	Chorus program vv=00H to 07H (default 02H) 00H: Chorus1 01H: Chorus2 02H: Chorus3 03H: Chorus4 04H: Feedback 05H: Flanger 06H: Short delay 07H: FB delay
CTRL 91	BnH 5BH vv	Reverb send level vv=00H to 7FH
CTRL 93	BnH 5DH vv	Chorus send level vv=00H to 7FH
CTRL 120	BnH 78H 00H	All sound off (abrupt stop of sound on channel n)
CTRL 121	BnH 79H 00H	Reset all controllers
CTRL 123	BnH 7BH 00H	All notes off
CTRL 126	BnH 7EH 00H	Mono on
CTRL 127	BnH 7FH 00H	Poly on (default power-up)
CTRL CC1	BnH ccH vvH	Assignable Controller 1. cc=Controller number (0-5Fh), vv=Control value (0-7Fh). Control number (ccH) can be set on CC1 CONTROLLER NUMBER (Sys.Ex. 40 1x 1F). The resulting effect is determined by CC1 controller function (Sys.Ex. 40 2x 40-4A)
CTRL CC2	BnH ccH vvH	Assignable Controller 2. cc=Controller number (00h-5Fh), vv=control value (0-7Fh). Control number can be set on CC2 CONTROLLER NUMBER (Sys.Ex. 40 1x 20). The resulting effect is determined by CC2 controller function (Sys.Ex.40 2x 50-5A).
RPN 0000H	BnH 65H 00H 64H 00H 06H vv	Pitch bend sensitivity in semitones (default=2)
RPN 0001H	BnH 65H 00H 64H 01H 06H vv	Fine tuning in cents (vv=00 -100, vv=40H 0, vv=7FH +100)
RPN 0002H	BnH 65H 00H 64H 02H 06H vv	Coarse tuning in half-tones (vv=00 -64, vv=40H 0, vv=7FH +64)
NRPN 0108H	BnH 63H 01H 62H 08H 06H vv	Vibrate rate modify (vv=40H -> no modif)

NRPN 0109H	BnH 63H 01H 62H 09H 06H vv	Vibrate depth modify (vv=40H -> no modif)
NRPN 010AH	BnN 63H 01H 62H 0AH 06H vv	Vibrate delay modify (vv=40H -> no modif)
NRPN 0120H	Bnh 63H 01H 62H 20H 06H vv	TVF cutoff freq modify(vv=40H -> no modif)
NRPN 0121H	BnH 63H 01H 62H 21H 06H vv	TVF resonance modify (vv=40H -> no modif)
NRPN 0163H	Bnh 63H 01H 62H 63H 06H vv	Env. attack time modify(vv=40H ->no modif)
NRPN 0164H	BnH 63H 01H 62H 64H 06H vv	Env. decay time modify(vv=40H -> no modif)
NRPN 0166H	BnH 63H 01H 62H 66H 06H vv	Env. release time modif(vv=40H ->no modif)
NRPN 18rrH	BnH 63H 18H 62H rr 06H vv	Pitch coarse of drum instr. note rr in semitones (vv=40H -> no modif) (note 2)
NRPN 1ArrH	BnH 63H 1AH 62H rr 06H vv	Level of drum instrument note rr (vv=00 to 7FH) (note 2)
NRPN 1CrrH	BnH 63H 1CH 62H rr 06H vv	Pan of drum instrument note rr (40H = middle) (note 2)
NRPN 1DrrH	BnH 63H 1DH 62H rr 06H vv	Reverb send level of drum instrument note rr (vv=00 to 7FH) (note 2)
NRPN 1ErrH	BnH 63H 1EH 62H rr 06H vv	Chorus send level of drum instrument note rr (vv=00 to 7FH) (note 2)
NRPN 37xxH	BnH 63H 37H 62H xx 06H vv	Special Synthesis features controls (see §2 above)
Standard Sysex	F0H 7EH 7FH 09H 01H F7H	General MIDI reset (note 4)
Standard Sysex	F0H 7FH 7FH 04H 01H 00H ll F7H	Master volume (ll=0 to 127, default 127) (note 5)
SYSEX	F0H 41H 00H 42H 12H 40H 00H 00H dd dd dd dd xx F7H	Master tune (default dd= 00H 04H 00H 00H) -100.0 to +100.0 cents. Nibblized data should be used (always four bytes). For example, to tune to +100.0 cents, sent data should be 00H 07H 0EH 08H (note 5)
SYSEX	F0H 41H 00H 42H 12H 40H 00H 04H vv xx F7H	Master volume (default vv=7FH) (note 5)
SYSEX	F0H 41H 00H 42H 12H 40H 00H 05H vv xx F7H	Master key-shift (default vv=40H, no transpose) (note 5)
SYSEX	F0H 41H 00H 42H 12H 40H 00H 06H vv xx F7H	Master pan (default vv=40H, center) (note 5)
SYSEX	F0H 41H 00H 42H 12H 40H 00H 7FH 00H xx F7H	GS reset (note 4)
SYSEX	F0H 41H 00H 42H 12H 00H 00H 7FH xx xx F7h	GS reset (note 5)
SYSEX	F0h 41H 00H 42H 12H 40H 01H 10H vv1 vv2 vv3 vv4 vv5 vv6 vv7 vv8 vv9 vv10 vv11 vv12 vv13 vv14 vv15 vv16 xx F7H	Voice reserve : vv1=Part 10 (default vv=2) vv2=Part 1 (default vv=6) vv3 to vv10=Part 2 to 9 (default vv=2) vv11 to vv16=Part 11 to 16 (default vv=0) (note 4)
SYSEX	F0H 41H 00H 42H 12H 40H 01H 30H vv xx F7H	Reverb type (vv=0 to 7), default = 04H 00H: Room1 01H: Room2 02H: Room3 03H: Hall1 04H: Hall2 05H: Plate 06H: Delay 07H: Pan delay (note 5)
SYSEX	F0H 41H 00H 42H 12H 40H 01H 31H vv xx F7H	Reverb character, default 04H (note 5)
SYSEX	F0H 41H 00H 42H 12H 40H 01H 32H vv xx F7H	Reverb pre-lpf, 00H to 07H, default 0H (note 5)
SYSEX	F0H 41H 00H 42H 12H 40H 01H 33H vv xx F7H	Reverb master level, default = 64 (note 5)
SYSEX	F0H 41H 00H 42H 12H 40H 01H 34H vv xx F7H	Reverb time (note 5)
SYSEX	F0H 41H 00H 42H 12H 40H 01H 35H vv xx F7H	Reverb delay feedback. Only if reverb number=6 or 7 (delays) (note 5)
SYSEX	F0H 41H 00H 42H 12H 40H 01H 38H vv xx F7H	Chorus type (vv=0 to 7), default = 02H (note 5) 00H: Chorus1 01H: Chorus2 02H: Chorus3 03H: Chorus4 04H: Feedback 05H: Flanger 06H: Short delay 07H: FB delay
SYSEX	F0H 41H 00H 42H 12H 40H 01H 39H vv xx F7H	Chorus pre-lpf, 00H to 07H, default = 0 (note 5)
SYSEX	F0H 41H 00H 42H 12H 40H 01H 3AH vv xx F7H	Chorus master level, default = 64 (note 5)
SYSEX	F0H 41H 00H 42H 12H 40H 01H 3BH vv xx F7H	Chorus feedback (note 5)
SYSEX	F0H 41H 00H 42H 12H 40H 01H 3CH vv xx F7H	Chorus delay (note 5)
SYSEX	F0H 41H 00H 42H 12H 40H 01H 3DH vv xx F7H	Chorus rate (note 5)
SYSEX	F0H 41H 00H 42H 12H 40H 01H 3EH vv xx F7H	Chorus depth (note 5)
SYSEX	F0H 41H 00H 42H 12H 40H 1pH 02H nn xx F7H	MIDI channel to part assign, p is part (0 to 15), nn is MIDI channel (0 to 15, 16=OFF). This SYSEX allows to assign several parts to a single MIDI channel or to mute a part.

		<p>Default assignment :</p> <table border="1"> <thead> <tr> <th>part</th> <th>MIDI channel</th> </tr> </thead> <tbody> <tr> <td>0</td> <td>9 (DRUMS)</td> </tr> <tr> <td>1-9</td> <td>0-8</td> </tr> <tr> <td>10-15</td> <td>10-15</td> </tr> </tbody> </table> <p>(note 3)</p>	part	MIDI channel	0	9 (DRUMS)	1-9	0-8	10-15	10-15
part	MIDI channel									
0	9 (DRUMS)									
1-9	0-8									
10-15	10-15									
SYSEX	F0H 41H 00H 42H 12H 40H 1pH 15H vv xx F7H	<p>Part to rhythm allocation, p is part (0 to 15), vv is 00 (sound part) or 01 (rhythm part). This SYSEX allows a part to play sound or drumset. There is no limitation of the number of parts playing drumset.</p> <p>Default assignment: part 0 plays drums (default MIDI channel 9) all other parts play sound.</p> <p>(note 3)</p>								
SYSEX	F0H 41H 00H 42H 12H 40H 1nH 40H v1 v2 ... v12 xx F7H	<p>Scale tuning, n is MIDI channel (0 to 15), v1 to v12 are 12 semi-tones tuning values (C, C#, D, ... A#, B), in the range -64 (00H) 0 (40H) +63(7FH) cents.</p> <p>This SYSEX allows non chromatic tuning of the musical scale on a given MIDI channel.</p> <p>Default v1, v2, ... ,v12 = 40H, 40H,...,40H (chromatic tuning).</p> <p>Scale tuning has no effect if the part is assigned to a rhythm channel or if the sound played is not of chromatic type.</p> <p>(note 3)</p>								
SYSEX	F0H 41H 00H 42H 12H 40H 1nH 1AH vv xx F7H	Velocity slope from 00H to 7FH (default = 40H) (note 3)								
SYSEX	F0H 41H 00H 42H 12H 40H 1nH 1BH vv xx F7H	Velocity offset from 00H to 7FH (default = 40H) (note 3)								
SYSEX	F0H 41H 00H 42H 12H 40H 1nH 1FH vv xx F7H	CC1 Controller number (00-5FH) (default = 10H) (note 3)								
SYSEX	F0H 41H 00H 42H 12H 40H 1nH 20H vv xx F7H	CC2 Controller number (00-5FH) (default = 11H) (note 3)								
SYSEX	F0H 41H 00H 42H 12H 40H 2nH 00H vv xx F7H	Mod pitch control (-24,+24 semitone) (default = 40H) (note 3)								
SYSEX	F0H 41H 00H 42H 12H 40H 2nH 01H vv xx F7H	Mod tvf cutoff control (default = 40H) (note 3)								
SYSEX	F0H 41H 00H 42H 12H 40H 2nH 02H vv xx F7H	Mod Amplitude control (-100%+100%) (default=40H) (note 3)								
SYSEX	F0H 41H 00H 42H 12H 40H 2nH 03H vv xx F7H	Mod lfo1 rate control (default = 40H). n is don't care. Rate is common on all channels								
SYSEX	F0H 41H 00H 42H 12H 40H 2nH 04H vv xx F7H	Mod lfo1 pitch depth (0-600 cents) (default=0AH) (note 3)								
SYSEX	F0H 41H 00H 42H 12H 40H 2nH 05H vv xx F7H	Mod lfo1 tvf depth (default = 0H) (note 3)								
SYSEX	F0H 41H 00H 42H 12H 40H 2nH 06H vv xx F7H	Mod lfo1 tva depth (0-100%) (default = 0H) (note 3)								
SYSEX	F0H 41H 00H 42H 12H 40H 2nH 10H vv xx F7H	Bend pitch control (-24,+24 semitone) (default = 42H) (note 3)								
SYSEX	F0H 41H 00H 42H 12H 40H 2nH 11H vv xx F7H	Bend tvf cutoff control (default = 40H) (note 3)								
SYSEX	F0H 41H 00H 42H 12H 40H 2nH 12H vv xx F7H	Bend Amplitude control (-100%+100%) (default=40H) (note 3)								
SYSEX	F0H 41H 00H 42H 12H 40H 2nH 14H vv xx F7H	Bend lfo1 pitch depth (0-600 cents) (default=0AH) (note 3)								
SYSEX	F0H 41H 00H 42H 12H 40H 2nH 15H vv xx F7H	Bend lfo1 tvf depth (default = 0H) (note 3)								
SYSEX	F0H 41H 00H 42H 12H 40H 2nH 16H vv xx F7H	Bend lfo1 tva depth (0-100%) (default = 0H) (note 3)								
SYSEX	F0H 41H 00H 42H 12H 40H 2nH 20H vv xx F7H	CAF pitch control (-24,+24 semitone) (default = 40H) (note 3)								
SYSEX	F0H 41H 00H 42H 12H 40H 2nH 21H vv xx F7H	CAF tvf cutoff control (default = 40H) (note 3)								
SYSEX	F0H 41H 00H 42H 12H 40H 2nH 22H vv xx F7H	CAF Amplitude control (-100%+100%) (default=40H) (note 3)								
SYSEX	F0H 41H 00H 42H 12H 40H 2nH 24H vv xx F7H	CAF lfo1 pitch depth (0-600 cents) (default=0AH) (note 3)								
SYSEX	F0H 41H 00H 42H 12H 40H 2nH 25H vv xx F7H	CAF lfo1 tvf depth (default = 0H) (note 3)								
SYSEX	F0H 41H 00H 42H 12H 40H 2nH 26H vv xx F7H	CAF lfo1 tva depth (0-100%) (default = 0H) (note 3)								
SYSEX	F0H 41H 00H 42H 12H 40H 2nH 40H vv xx F7H	CC1 pitch control (-24,+24 semitone) (default = 40H) (note 3)								
SYSEX	F0H 41H 00H 42H 12H 40H 2nH 41H vv xx F7H	CC1 tvf cutoff control (default = 40H) (note 3)								
SYSEX	F0H 41H 00H 42H 12H 40H 2nH 42H vv xx F7H	CC1 Amplitude control (-100%+100%) (default=40H) (note 3)								
SYSEX	F0H 41H 00H 42H 12H 40H 2nH 44H vv xx F7H	CC1 lfo1 pitch depth (0-600 cents) (default=0AH) (note 3)								

	F7H	
SYSEX	F0H 41H 00H 42H 12H 40H 2nH 45H vv xx F7H	CC1 lfo1 tvf depth (default = 0H) (note 3)
SYSEX	F0H 41H 00H 42H 12H 40H 2nH 46H vv xx F7H	CC1 lfo1 tva depth (0-100%) (default = 0H) (note 3)
SYSEX	F0H 41H 00H 42H 12H 40H 2nH 50H vv xx F7H	CC2 pitch control (-24,+24 semitone) (default = 40H) (note 3)
SYSEX	F0H 41H 00H 42H 12H 40H 2nH 51H vv xx F7H	CC2 tvf cutoff control (default = 40H) (note 3)
SYSEX	F0H 41H 00H 42H 12H 40H 2nH 52H vv xx F7H	CC2 Amplitude control (-100%+100%) (default=40H) (note 3)
SYSEX	F0H 41H 00H 42H 12H 40H 2nH 54H vv xx F7H	CC2 lfo1 pitch depth (0-600 cents) (default=0AH) (note 3)
SYSEX	F0H 41H 00H 42H 12H 40H 2nH 55H vv xx F7H	CC2 lfo1 tvf depth (default = 0H) (note 3)
SYSEX	F0H 41H 00H 42H 12H 40H 2nH 56H vv xx F7H	CC2 lfo1 tva depth (0-100%) (default = 0H) (note 3)

Notes:

1. NRPN sending method: CTRL#99=high byte, CTRL#98=low byte, CTRL#6=vv
 Example: NRPN 0108H = 40H -> CTRL#99=1, CTRL#98=8, CTRL#6=64

x or xx means “ don’t care ”

2. Drumset edit Nrpn:

4 different drumset edit tables are implemented:

- 1 for midi port 1 channel 10
- 1 for midi port 2 channel 10
- 1 for midi port 1 channels 1-9 or 11-16: for all these channels, edit table is the same
- 1 for midi port 2 channels 1-9 or 11-16: for all these channels, edit table is the same

3. Cross system exclusive:

Address can be 040h xxh xxh or 050h xxh xxh

If address=040h xxh xxh: system exclusive applies to midi port 1 (midi channels 0-Fh) if received on midi port 1, applies to midi port 2 (midi channels 10-1Fh) if received on midi port 2.

If address=050h xxh xxh, cross system exclusive: applies to port 2 if received on port 1, applies to port 1 if received on port 2

4. Non cross system exclusive applying only on receiving port:

System exclusive applies to midi port 1 (midi channels 0-Fh) if received on midi port 1.

System exclusive applied to midi port 2 (midi channels 10-1Fh) if received on midi port 2.

5. Non cross system exclusive applying on both ports:

System exclusive will be applied to all midi channels (0-1Fh). Can be received on port 1 or port 2 indifferently.

This is the case for all system exclusive concerning reverb and chorus because reverb and chorus are the same for both ports 1 and 2.

4. MPU401 INTERFACE

MPU401 standard parallel interface is available together with serial midi.

I/O Interface

The I/O Interface is composed of two byte registers, and one IRQ:

I/O address	Write from PC (OUT)	Read to PC (IN)
MPU_base + 0	DATA8	DATA8
MPU_base +1	CONTROL	STATUS

The byte registers provides compatibility with the standard MPU401 UART mode. The control message is sent on CONTROL register with one data on DATA8 register. The read back values (if any) are available on DATA8 register. The IRQ (PC compatible rising edge) is compatible with MPU401 interrupt. It is floated until the MPU401 interface is switched to UART mode, to minimize potential IRQ conflicts.

IO Status Register:

TE	RF	ID1	ID0	X	X	X	X
----	----	-----	-----	---	---	---	---

TE : Transmit empty.

If 0, data from SAM2634 to PC is pending and IRQ is high. Reading the data at MPU_BASE+0 will set TE to 1 and clear IRQ.

RF: Receiver full.

If 0 then SAM2634 is ready to accept CONTROL or DATA from the PC.

TE and RF are MPU401 compliant. Two additional bits ID1 ID0 are provided. They allow to identify the logical SAM2634 device read DATA8 as follows :

ID1	ID0	Device
0	0	MIDI
0	1	Reserved
1	0	Reserved
1	1	General

Serial & Parallel modes

Serial mode:

After power-up, hardware reset or Parallel mode reset control, the board is in stand-alone mode. In Serial mode, SAM2634 plays whatever is received on the MIDI IN serial line, MIDI OUT is disabled. Serial mode enables only 1 control on parallel interface:

3Fh to switch to Parallel mode.

3Fh control is acknowledged by receiving 0FEh as DATA8 with ID(1,0)=00 (Midi device).

Parallel mode:

This mode is mpu401 uart mode compliant :

- Midi messages don't require any CONTROL but only DATA.
- Writing DATA8 will send MIDI data to MIDI OUT and the wavetable synthesis: 2 midi ports of 16 channels each are available. Sending control 0B0h selects midi port 1, sending control 0B1h selects midi port 2.
- Port 1 and port 2 can also be selected by writing 2 DATA8 bytes (0F5h 01h or 0F5h 02h, see paragraph 1.6)

- MIDI data received from MIDI IN can be read as DATA8 with ID0-1=00.
- Control 0FFh (Parallel mode reset) switch back to Serial mode.

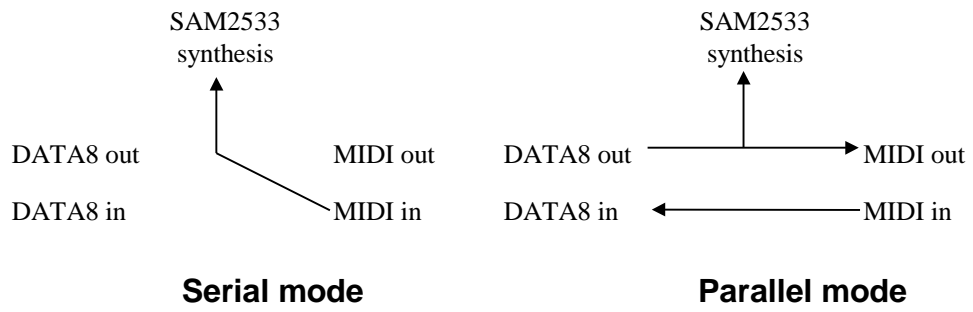

Midi message path

5. AUTO-TEST

Built-in auto-test program is included which can be used for board production testing.
To start auto-test, send NRPN 3751H = 23H

Sine waveforms at different frequencies will be output to the DAC to indicate test in progress, as follows:

Test in progress	Output frequency
Internal RAM	1.4 kHz
External FLASH	1.0 kHz
PASS	700 Hz

Notes:

- For using external flash test, flash binary file must be created using Dream program 94SPLIT4.EXE. This program automatically inserts in last word of binary file checksum of binary file. During flash test, autotest function performs checksum and compares this checksum with last word read in flash.
- Last sine waveform is output constantly to allow test of audio output. Board must be reset to exit test mode and return in normal mode.

APPENDIX 1 : Spatial Effect structure

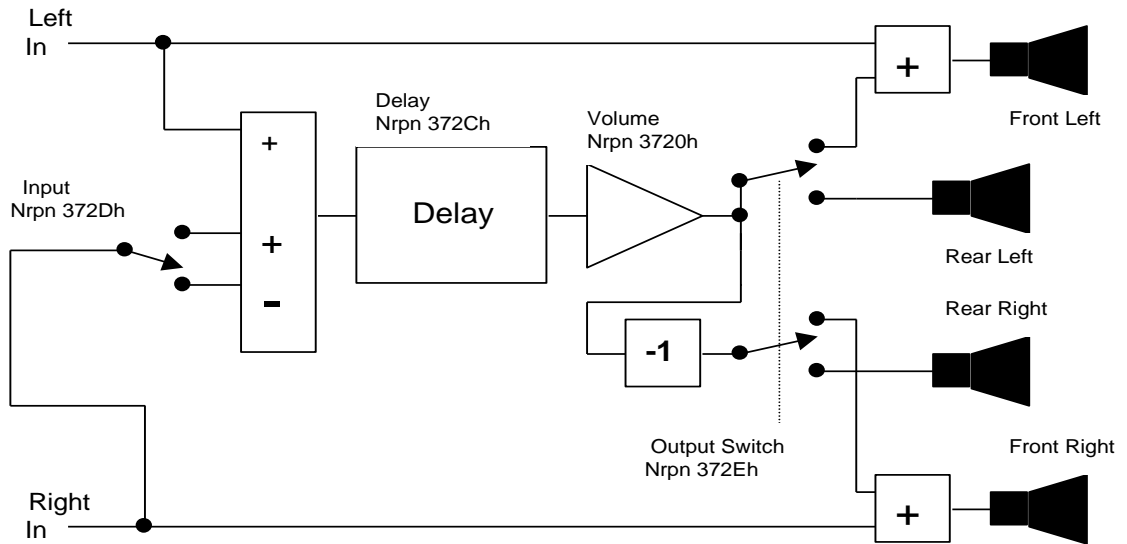

APPENDIX 2: Microphone echo structure

Dream echo structure includes 3 echos. Main one is the master echo: master echo time T is set with nrpn 3729h while feedback is set with nrpn 372Ah. Slave 1 and Slave 2 are 2 more echos delayed from master echo.

Slave1 is Master - $2T/3$

Slave2 is Master - $T/3$

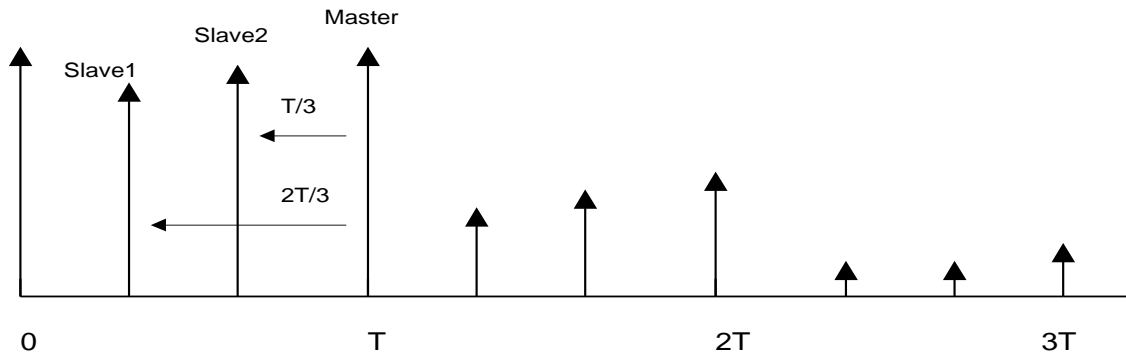

Volume of Master, Slave1 and Slave2 can be separately set using nrpn 3730h to 3735h. For example, for having mono echo (preset 0), slave1 and slave2 must be muted. Left and right volumes can be set independently for providing best stereo effect.

APPENDIX 3: Microphone key detect and level detect

This module may be used for scoring singer performance.

Be sure module has been set ON with Nrn 3756h (see paragraph 1.4, SCO bit=1).

This module is applied only on Mike 1 (DAAD Left input).

The microphone detection module provides 2 informations :

- Microphone level :

Microphone level information is sent through serial MIDI OUT, channel 1, using control 7.

Information is approximately updated every 100ms.

Range is about 0 till 60 maximum. Linear range.

For example:

B1h 07h 03h (mike level = 3)

B1h 07h 10h (mike level=10h)

- Microphone Key

Key detected is sent also through serial MIDI OUT, channel 0, using standard midi note ON and midi note OFF message.

In case of note ON message, velocity is always 060h.

For example:

90h 45h 60h: note 45h being sung

90h 45h 00h: note 45h off

Latency parameter (NRPN 3741h) controls duration of note detected by Key detection module.

For example, with default value of 24 (18h), note will be detected only if note is longer than about 1 second. For note shorter than 1 second, nothing will be detected and no information is sent on midi out.

With default value of 24, key detection module is working well and note detected almost always (95%) matches the real note sung by singer.

If using lower values, key detection module can also detect short notes but with a lot of errors. For example, with value=2, time response is 100ms but percentage of errors is near 50% ! Errors does not mean that the singer is not singing well ! Errors are due to simple and low quality algorithm used for doing key detection.

Nrn # High Low	Midi Message	Midi Code (Hexadecimal)	Description	Default Value
3741h	Control 99=55 Control 98=65 Control 6 = vv	B0h 63h 37h B0h 62h 41h B0h 06h vvh	Latency period for key detection response vv=0 to 127	24

Midi message path when scoring on

When scoring function is on the Midi message path is affected. (See figure below).

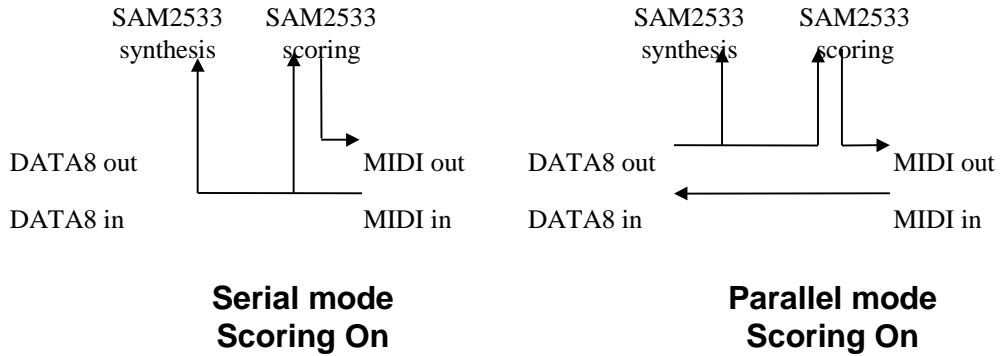

Midi message path when scoring off

When scoring function is off the Midi path is the standard one.

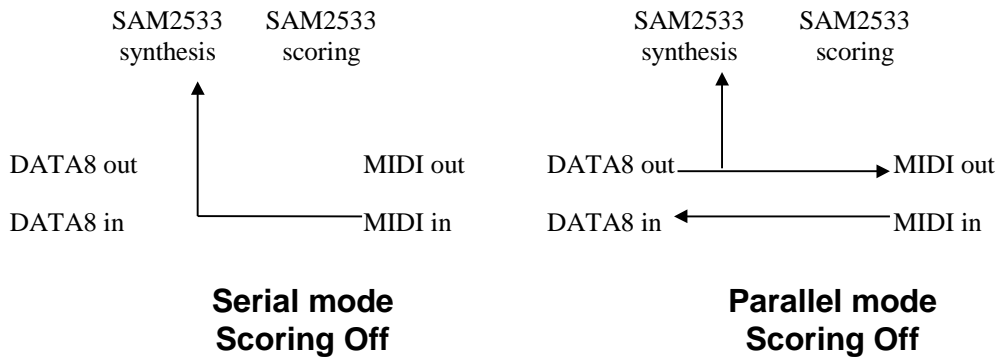

APPENDIX 4: Microphone Pitch Shift

Different pitch shift presets have been defined and can be applied independently to both microphone 1 and 2.

First 11 presets (robot voice and mickey mouse voice presets) are funny effect presets. These presets can be used for speech but not while singing.

Last 4 presets (doubler presets) can be used while singing : they have a chorusing effect on singer voice.

Nrpn # High Low	Midi Message	Midi Code (Hexadecimal)	Description	Default Value
373Ch	Control 99=55 Control 98=60 Control 6 = vv	B0h 63h 37h B0h 62h 3Ch B0h 06h vvh	Select Pitch Shift Preset for Microphone 1 vv=0 : OFF vv=1 to 15 : select preset 1 to 15	00
373Dh	Control 99=55 Control 98=61 Control 6 = vv	B0h 63h 37h B0h 62h 3Dh B0h 06h vvh	Select Pitch Shift Preset for Microphone 2 vv=0 : OFF vv=1 to 15 : select preset 1 to 15	00

Preset List:

- Preset 1: Robot Voice 1
- Preset 2: Robot Voice 2
- Preset 3: Robot Voice 3
- Preset 4: Robot Voice 4
- Preset 5: Robot Voice 5
- Preset 6: Mickey Mouse Voice 1
- Preset 7: Mickey Mouse Voice 2
- Preset 8: Mickey Mouse Voice 3
- Preset 9: Mickey Mouse Voice 4
- Preset 10: Mickey Mouse Voice 5
- Preset 11: Mickey Mouse Voice 6
- Preset 12: Light Doubler
- Preset 13: Medium Doubler
- Preset 14: Strong Doubler
- Preset 15: Low Octave Doubler

Dream Contact info@dream.fr

Website
<http://www.dream.fr>

This publication neither states nor implies any warranty of any kind, including, but not limited to, implied warrants of merchantability or fitness for a particular application. Dream assumes no responsibility for the use of any circuitry. No circuit patent licenses are implied. The information in this publication is believed to be accurate in all respects at the time of publication but is subject to change without notice. Dream assumes no responsibility for errors and omissions, and disclaims responsibility for any consequences resulting from the information included herein.

© Copyright 2006-2014 Dream S.A.S. France