

1. Making connections

- Connect the Front panel to the main board
- Connect the main board to a FATAR TP10 (or TP40) keyboard
- Connect The main board to pedal (see table below for pinout)
- Connect the main board audio outputs to line level inputs of a mixer, a stereo sound system...
- Connect the main board to 12V/1A DC power supply (- to tip , +to ring)

Pedal Inputs (J18) Pinout

Pin #	Function	Description
1	Pedal Ground	Reference Ground for pedal inputs
2	Forte (Sustain)	4-level Half-pedal <ul style="list-style-type: none">• Sustain Max if connected to Pedal Ground• Sustain Off if not connected
3	Sostenuto	On/Off pedal <ul style="list-style-type: none">• Sostenuto on if connected to Pedal Ground• Sostenuto off if not connected
4	Una Corda (Soft)	On/Off pedal <ul style="list-style-type: none">• Soft on if connected to Pedal Ground• Soft off if not connected

2. Front Panel

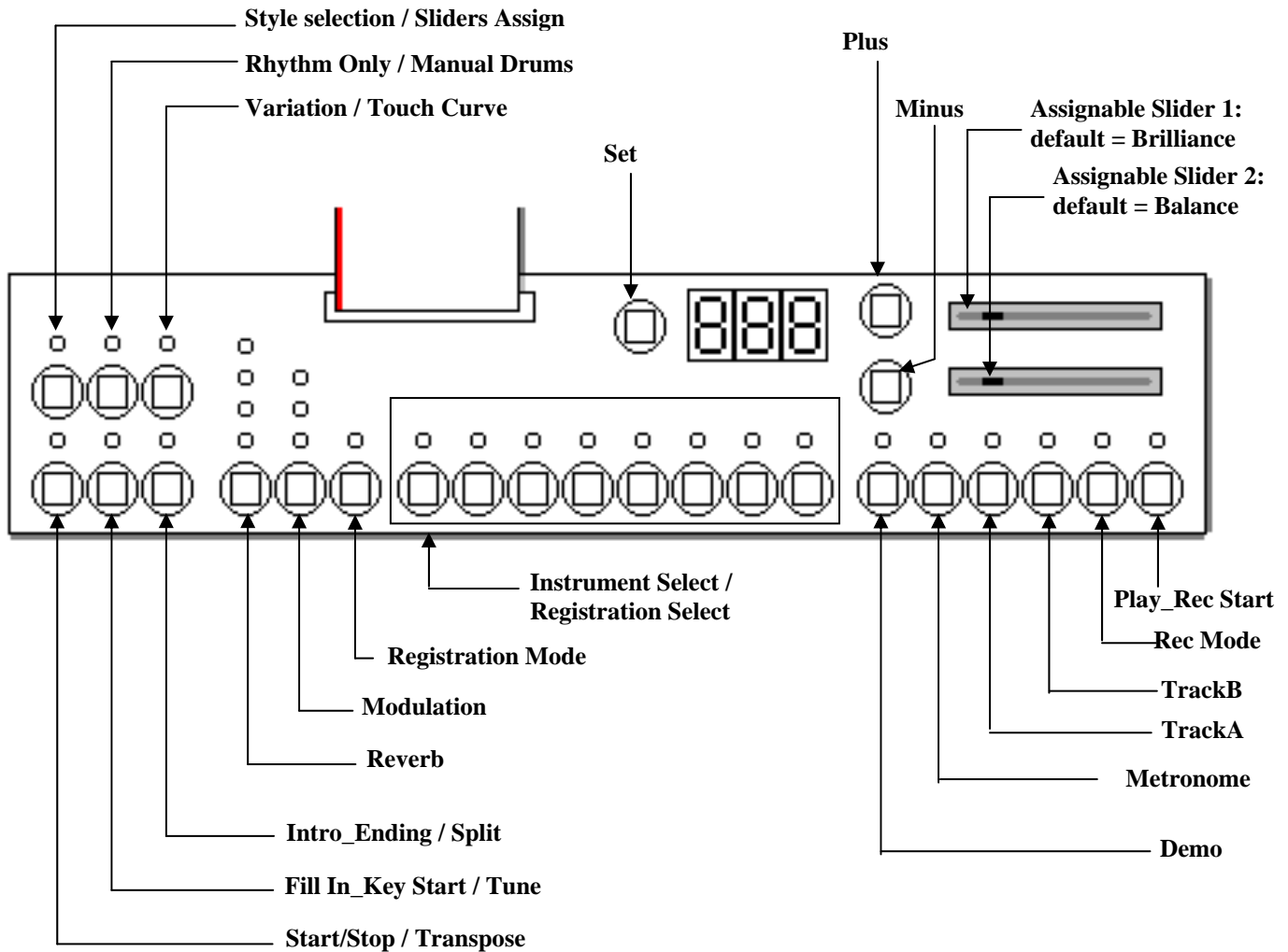

3. Functions

Instrument Select:

- | | |
|------------------------|------------------------|
| 1: Studio Grand Piano, | 2: Concert Grand Piano |
| 3: Electric Piano 1 | 4: Electric Piano 2 |
| 5: Harpsichord | 6: Vibes |
| 7: Strings | 8: Choir |

Layer (Dual) mode is available by simultaneously pressing two "Instrument Select" buttons.

Double function buttons:

There are two different firmwares for 3516PIA-DK.

- 3516PIA-ST is firmware version with Style player
- 3516PIA is firmware without Style player

All buttons have same functions in the two versions except that 6 of them have double functions in 3516PIA-ST. To alternate between the two sets of functions just press "Plus" and "Minus" buttons at the same time.

Blinking point in right down corner of the LED display shows that double functions buttons are In Style player mode.

Button	Function in 3516PIA	Default Function in 3516PIAS	Alternate Function in 3516PIAS
Start_Stop / Transpose	Transpose	Transpose	Start_Stop
Intro_Ending / Split	Split	Split	Intro_Ending
Style Selection / Sliders Assign	Sliders Assign	Sliders Assign	Style Selection
Fill In_Key Start	Tuning	Tuning	Fill In_Key Start
Rhythm Only	Manual Drums	Manual Drums	Rhythm Only
Variation	Touch Curve	Touch Curve	Variation

Split:

- Press the "Split" button to activate Split function. "Split" LED will turn on.
- If Dual mode is activated
- First selected sound in previous Dual mode is played on left of the split point (Lower sound). It is transposed one octave up.
 - Second selected sound in previous Dual mode is played on right of the split point (Upper sound)
- If not in Dual mode
- Current selected sound is played on right of the split point (Upper sound)
 - Strings sound is played on left of the split point (Lower sound). It is transposed one octave up.
- Default split point is G2 (MIDI note #55). Split point can be changed:
- Press and hold the "Split" button, then press a key on the keyboard. The pressed key becomes the lower note for the Upper sound. Its MIDI number is displayed.
- Change the Upper sound
- Press one of the 8 instrument buttons
- Change the Lower sound
- Press and hold the "Split" button, then press one of the 8 instrument buttons

Transpose:

- Global transpose is available in the range (-12,+12 semitones)
- Press and hold the "Transpose" button, then press the "Plus" or "Minus" button to specify the desired transposition value. The "Transpose" LED will turn on, indicating that the transpose function has been activated. The current transpose setting will be shown in the display.
 - To cancel transpose, select value "0" or press again the "Transpose" button. "Transpose" LED will turn off.
- Transposition value is memorised until power off.
- To recall memorized transposition, press the "Transpose" button. "Transpose" LED will turn on.

Tuning:

- Global tuning is available in the range (427.0, 453.0Hz)
- Press "Tuning" button. The "Tuning" LED will turn on. Default value is 440.0Hz. Display shows 40.0
 - Use the "Plus" or "Minus" button to specify the desired tuning value. Display is 27.0 ~ 53.0. Steps are 0.5Hz.
 - Press "Tuning" button to quit.

Reverb Type: Room / Hall1 / Hall2 / Stage.

- Reverb depth can be set for each instrument. Follow the steps below:
- Hold the "Reverb" button pressed
 - Use the "Plus" and "Minus" buttons for adjusting the reverb depth in the range 0-20

Modulation effect: Chorus / Phaser / Tremolo.

- Modulation Effect depth can be set for each instrument. Follow the steps below:
- Hold the "Modulation" button pressed
 - Use the "Plus" and "Minus" buttons for adjusting the effect depth in the range 0-20

Touch Curve: Soft / Medium / Hard / Constant Velocity (default = 64)

Touch curve can be selected for each instrument

- Press the "Touch Curve" button. The "Touch Curve" LED will turn on. Default value for current selected instrument will be displayed: "S F t" message for Soft curve, "M E d" for Medium curve, "H r d" for Hard curve and "C S t" for Constant curve
- Press the "Touch Curve" button again for exit.

The value for the constant velocity can be set:

- While constant curve is selected, hold the "Touch Curve" button pressed until the display shows the current constant dynamic value.
- Use the "Plus" and "Minus" buttons for adjusting the constant dynamic in the range 0-127

Demo:

Press "Demo", then press "Instrument Select" button 1, 2 or 3.

Metronome: On / Off.

The metronome signature can be set. Follow the steps below:

- Hold the "Metronome" button
- Use the "Plus" and "Minus" buttons for choosing the signature. Available signatures are 1/4, 2/4, 3/4, 4/4, 6/4, 6/8, 12/8
- Press "Set" button to display metronome volume. Metronome volume can be adjusted from "1" to "20" with the "Plus" and "Minus" buttons.

Piano Sequencer

A 4-track, 3-song sequencer is implemented in 3516PIA-DK. Sequencer functions are handled with "Rec Mode", "Play/Rec Start", "Track A", "Track B" and "Set" buttons.

Rec Mode:

- Should be pressed before starting a track record. Then, track to be recorded can be selected.
- Allow to stop the track record.

Play/Rec Start:

- Start playing the selected recorded song
- Stop playing the selected recorded song

Track A:

- Select the track to record if even track
- Mute/demute even track of the selected track pair

Track B:

- Select the track to record if odd track
- Mute/demute odd track of the selected track pair

Set:

- Access to "Song select" and "Track pair select". Displayed values can be changed with "Plus" and "Minus" buttons.

Below is an example on how to use the sequencer.

Select song 2

- Press "Set" button once. Display is "S n.1 ". Press "Plus" button to display "S n.2 ". Song #2 is selected.

Select track pair 3-4

Press "Set" button once. Display is "t.1.2 ". Press "Plus" button to display "t.3.4 ". Track pair 3-4 is selected. You can switch back to tempo display by pressing few times "Set" button.

Record track 3:

- Press "Rec Mode" button. "Rec Mode" led is lit.
- Press "Track A" button. "Play/Rec Start" and "Track A" leds are flashing.
- *Note: At this step, track 3 record operation can be cancelled by pressing "Rec Mode" button.*
- Start the recording by playing the keyboard or by pressing one pedal. "Play/Rec Start" led stops flashing and stays lit.
- Stop recording by pressing the "Rec Mode" button. "Rec Mode" and "Play/Rec Start" leds are off.

Play track 3:

- "Track A" led is lit to show that there are data recorded in track 3.
- Press the "Play/Rec Start" button for playing what is recorded on track 3. The "Play/Rec Start" led is lit.

Record track 4:

- Press the "Rec Mode" button. "Rec Mode" and "Track A" leds are lit.
- Press the "Track B" button. "Play/Rec Start" and "Track B" leds are flashing
- *Note: At this step, track 4 record operation can be cancelled by pressing "Rec Mode" button.*
- Start the recording by playing the keyboard or by pressing one pedal. "Play/Rec Start" led stops flashing and stays lit.
- Stop recording by pressing the "Rec Mode" button. "Rec Mode" led is off.

Play track 3 and track 4:

- "Track A" led is lit to show that there are data recorded in track 3.
- "Track B" led is lit to show that there are data recorded in track 4.
- Press the "Play/Rec Start" button for playing what is recorded on track 3 and track 4. The "Play/Rec Start" led is lit.

Delete song:

- Press "Set" button to get song selection menu. Use "Plus" and "Minus" buttons to select the song to delete.
- While keeping "Rec Mode" button pressed, press "Play/rec Start" button. Selected song is immediately deleted.

Manual Drums:

Manual Drums function will select a Drum kit that can be played on keyboard. This feature can be used to record Drum track (10) in sequencer.

- Press "Manual Drums" button to get drum kit instruments on keyboard. "Manual Drums" LED will turn on.
- Use "Instrument select" buttons to choose from the 8 available drum kits.
- Press "Manual Drums" button again to switch back to piano mode. "Manual Drums" LED will turn off.

Available drum kits are:

- o 1: Standard Set
- o 2: Room Set
- o 3: Power Set
- o 4: Electric Set
- o 5: TR808 Set
- o 6: Jazz Set
- o 7: Brush Set
- o 8: Orchestra

Mike setting:

Press few times on “Set” button until you get “**M i c**” on the LED display. Then press “Plus” button to put the mike input On with low reverb level. Display will be “**M.i c**”. Pressing again “Plus” button again will increase the reverb level and display will be “**M.i.c**”, then “**M.i.c.**”.

Sliders assign:

The two sliders can be allocated to various functions. To switch between the available functions:

- Press and hold the “Sliders Assign” button, then press the “Plus” or “Minus” button to choose the function

Available functions are

- Volume balance: Display is “**b A L**”. Slider 1 is Brilliance adjustment Slider 2 is volume Balance between the two sounds if in Split mode or in Dual Mode
- GM Level. Display is “**G M.L**”. Slider 1 is general volume for GM Sound module played by MIDI File player, Style player, MIDI IN or USB MIDI

Only if Style player

- Accompaniment volumes. Display is “**A c c**”. Slider1 is Bass & Drums volume and slider 2 is volume for the others 5 style player tracks.

SDCard (SD) Functions

General information: In the current version, 3516PIA-DK firmware support SDCard with FAT16 (up to 4 GByte) or FAT32 file systems.

Only Standard MIDIFile in format 0 are supported. Maximum File size is 33 kByte

Up to 3 SMF can be stored at the same time in the internal memory.

SD functions can be acceded by pressing repetitively on the “Set” button until the display shows “**S d. C**”. Then following functions can be used:

SD Scroll:

Scroll across SDCard MIDIFiles.

- Press the first “Instrument select” button. Display toggles between “**F i l**” and “**S.xx**” or “**F.x x**” if one SD that contains Standard MIDIFiles (SMF) is inserted in SDMMC socket. If no SD inserted or SD without SMF, display will toggle between “**F i l**” and “- - -”.
- Use “Plus” and “Minus” buttons to select the SMF that you want to load or to delete.
 - SMF with name included 2 digits in 4th and 5th characters be displayed in format “**S.x x**”. **xx** is the value of the 2 digits in name.
Example: “SONG56.MID” will be displayed as “**S.5 6**”.
 - If name of SMF doesn’t include 2 digits in 4th and 5th characters, display will be “**F.x x**”. **xx** is the value of the index of the song in the SD directory.
Example: “PRELUDE.MID” can be displayed as “**F.0 2**” if it is referenced at the index 2 of the SD directory.

Play File from SD:

When in SD Scroll mode you can play directly from SD the File that is currently displayed. For that, simply press the “Play/Rec Start” button.

Load File from SD:

Load File from SD to internal memory. This menu can be reached only if SD that contains SMF is inserted

- Press the second “Instrument select” button. Display toggles between “**L d.F**” and “**Y E S**”
- Pressing the “Plus” button now, will load the latest SMF that was selected with SD Scroll function to current selected song of sequencer. If load operation succeeds, then display will go back to tempo. If file is too big for internal memory, load operation will abort and display will show “**b l g**”. If file is not a valid SMF format 0, load operation will abort and display will show “**b a d**”.
- Pressing the “Minus” button will cancel the Load operation and escape from SD Functions.

Save Song to SD:

Save the current sequencer Song to SD in SMF format. This menu can be reached only if unlocked SD that contains SMF is inserted

- Press the third “Instrument select” button. Display toggles between “**S A.F**” and “**S.0 0**”
- Use “Plus” and “Minus” buttons to choose the number you will add in the song name. If display is “**S.0 7**”, song will be saved on SD with name SONG07.MID.
- Press again the third “Instrument select” button. Display toggles between “**S A.F**” and “**Y E S**”
- Pressing the “Plus” button now, will save the last selected sequencer song as SMF in SD.
- Pressing the “Minus” button will cancel the Save operation and escape from SD Functions.

Delete SD File:

Delete File of SD. This menu can be reached only if unlocked SD that contain SMF is inserted

- Press the fourth “Instrument select” button. Display toggles between “**d l.F**” and “**Y E S**”
- Pressing the “Plus” button now, will delete the latest SMF that was selected with SD Scroll function
- Pressing the “Minus” button will cancel the Delete operation and escape from SD Functions.

Advanced Functions

Some advanced functions can be configured by pressing repetitively on the “Set” button until the display shows “**F n c**”.

Then following functions can be adjusted:

Lower Octave Shift:

Octave shift for the lower sound.

- Press the first “Instrument select” button. Display toggles between “**L.O.S**” and “ **1** ”. Use “Plus” and “Minus” buttons to select the octave shift in range “0-2”.

Damper Pedal Assign:

Damper pedal can be assigned to Upper sound or lower sound or to both.

- Press the second “Instrument select” button. Display toggles between “**d.P d**” and “**L _ U**”. It means that Damper pedal is assigned to Upper and Lower sounds.
- Use “Plus” and “Minus” buttons to select “ **_ U** ” (Damper pedal assigned only for Upper sound) or “**L _** ” (Damper pedal assigned only for lower sound).

Temperament:

Various historical temperaments other than the modern “equal” can be selected.

- Press the third “Instrument select” button. Display toggles between “**t M P**” and “**T P.1**”. It means that temperament #1 is currently selected.
- Use “Plus” and “Minus” buttons to select another temperament through the 7 available.
Available temperaments are:

- o TP.1: Equal
- o TP.2: Pythagorean
- o TP.3: Pure Major
- o TP.4: Pure Minor
- o TP.5: Mean Tone
- o TP.6: Werckmeister III
- o TP.7: Kirnberger III

Root Note:

Root note should be specified for temperaments others than the Equal one.

- Press the fourth “Instrument select” button. Display toggles between “**r t.n**” and “ **C** ”. It means that root note for is currently selected temperament is C.
- Use “Plus” and “Minus” buttons to select another root note. “ **C** ‘ “ in display means C#.

Sympathetic Notes: (for piano sound)

Sympathetic notes are resonances of held notes that are played by sympathy with other notes of the same harmonic series. This piano effect is only available with piano sounds 1 and 2.

- Press the fifth “Instrument select” button. Display toggles between “**S y.n**” and “ **10** ”. It means that current volume for Sympathetic notes is “10”.
- Use “Plus” and “Minus” buttons to adjust Sympathetic notes volume in range 0 - 20.

Damper Effect: (for piano sound)

Damper effect simulates the sound of all strings freely vibrating in sympathetic resonance when notes are played with damper pedal depressed. This piano effect is only available with piano sounds 1 and 2.

- Press the sixth “Instrument select” button. Display toggles between “**.d M P**” and “ **10** ”. It means that current volume for Damper effect is “10”.
- Use “Plus” and “Minus” buttons to adjust Damper effect level in range 0 - 20.

Registrations

Presets can be stored in 8 Registrations. Registrations are memorized even after power off.

Registrations retain the following parameters:

- Reverb Type
- Reverb Volume
- Chorus Type
- Chorus Volume
- Touch Curve
- Tempo
- Upper Sound
- Lower Sound
- Upper Volume
- Lower Volume
- Split On/Off
- Split point
- Transpose
- Tune
- Temperament
- Root Note
- Lower Octave Shift
- Damper Pedal Assign

If 3516PIA-ST parameters below are also stored:

- Style #
- Variation #
- Style player 1 Volume (Bass & Drum)
- Style player 2 Volume (All parts except Bass & Drum)
- Rhythm Only On/Off

To save your current setting in one registration, do the next steps:

- Check that the “Registration” LED is off. If it is On, press the “Registration” button to quit the registration mode.
- Adjust all parameters until you get the setting that you want to save in one registration.
- Press and hold “Registration” button while you press one of the 8 “Instrument select” buttons. The current setting is now stored in the registration corresponding to the “Instrument Select” button that you have pressed.

To recall a registration:

- Enter registration mode by pressing “registration” button. “Registration” LED is On to show that you are in registration mode. By default Registration1 is recalled and LED of first “Instrument Select” is On.
- To recall another registration, just press the corresponding “Instrument” select button.

To exit registration mode:

Press the “Registration” button to get the “Registration” LED Off

MIDI

Midi parameters can be configured by pressing repetitively on the “Set” button until the display shows “M i d”. Then following parameters can be adjusted:

Transmit channel:

Transmit channel is MIDI transmit channel for keyboard upper notes. Keyboard lower/dual notes will be transmitted on next greater channel.

- Press the first “Instrument select” button. Display toggles between “t r.C ” and “ 1 ”. Use “Plus” and “Minus” buttons to select the Midi transmit channel in range “1-16”

Local Control On/Off:

Local Control On/Off function allows connecting or not the Sound engine to Keyboard. If Local Control is On keyboard can play sound engine and send notes info to MIDI out. If Local Control is Off keyboard is not connected to sound engine but it continues to send notes info to MIDI out.

- Press the second "Instrument select" button. Display toggles between "L c l" and "O n". Use "Plus" and "Minus" buttons to set the Local control to "O n" or "O f f"

Program Change On/Off:

Program Change On/Off function decides if Program Change are received and transmitted by 3516PIA-DK.

- Press the third "Instrument select" button. Display toggles between "P G.C" and "O n". Use "Plus" and "Minus" buttons to set value to "O n" or "O f f"

Piano Mode On/Off:

Piano Mode On/Off decides how the MIDI In channels 1 and 2 will be played:

If Piano Mode is On, MIDI in channels 1 and 2 are played with piano effects (Sympathetic notes and Damper effect) when piano sounds are selected (MIDI Program 0 and 1). GM chorus is not available for these two channels. MIDI In channels 3-16 will not have the piano effects but the standard GM chorus instead

If Piano Mode is Off, MIDI In channels 1-16 will not have the piano effects but the standard GM chorus instead.

By default, Piano mode is On. Receiving a system exclusive message GM Reset or GS Reset on MIDI In will switch off the Piano mode. Piano mode setting can also be done manually:

- Press the fourth "Instrument select" button. Display toggles between "P M d" and "O n". Use "Plus" and "Minus" buttons to set the Piano mode "O n" or "O f f"

Factory Reset

3516PIA can be restored as it was at its first power-up by pressing the higher note of the keyboard while power-up. Following actions will be done:

- Instruments will recover their factory effect and touch curve settings.
- Registrations will be restored to their factory default.

Optional Functions (for 3516PIA-ST only)

Style player: Use "Intro_Ending", "Fill-In", "Start_Stop", "Variation", "Rhythm Only", "Style selection" buttons.

Easy Chord mode for beginners can be activated by pressing "Style selection" button, then "Set" button"

Style Selection: Press the "Style Selection" button then select with "Plus" and "Minus" buttons.

0: EuroPop,	1: 90sDance,
2: KickDance,	3: 80sPop,
4: TechnoRock,	5: Country,
6: Beguine,	7: Bossa,
8: Blues,	9: JazzTet,
10: Rock&Roll,	11: Soca,
12: Lounge,	13: Waltzer

4. Feature Table

FEATURES	DETAILS
Sounds	8 sounds selectable from panel 128 GM sounds + 99 variations selectable from MIDI Manual Drums
Memory for 8 high quality sounds	32 MByte
Memory for GM sound + variations.	4 MByte
Sound Engine	32-parts Multitimbral high range Wavetable Synthesizer
Polyphony	Up to 135 voices
Display	3-digit LED
Effect	Reverb (Room, Hall1, Hall2, Stage) Modulation (Chorus, Phaser, Tremolo)
Sliders	2, assignable: Brilliance and Balance (default) Style player volumes* GM module volume
Metronome	Time signature: 1/4, 2/4, 3/4, 4/4, 6/4, 6/8, 12/8 32-250 bpm with volume control
Sequencer	3 songs, 4 dual tracks per song, 15 000 event per song SMF format 0, storage in DataFlash
Demo	3 demo songs
Registrations	8 registrations for user Storage in DataFlash
Touch Curve	Soft, Medium, Hard, Constant (programmable from 0 to 127 by user)
Dual	2-sound layer with volume balance
Split	Programmable Split point
Transpose	-12 to +12 semi-tones
Tune	427 to 453 Hz
Temperaments	Equal, Pythagorean, Pure Major, Pure Minor, Mean Tone, Werckmeister III, Kirnberger III Programmable Root Note
USB	USB MIDI (to Host) Soundbank, Demo and Style* update
SD Card	SDMMC socket. SD Card support, up to 4 GByte Save sequencer song in SMF format 0, Read SMF, Load SMF format 0, Delete SMF
Style Player*	8-part, 2-group style player 1 volume per group 14 Styles with Intro, Ending, Fill in, Variation Start-Stop, Rhythm Only, Easy Chord
Pedals	Damper (4 levels), Sostenuato, Soft
Reset	Recall of factory Registrations and settings
Production Test	Test for front panel: Leds, Display, Switches, Pedals, Sliders Test for soundboard components: SAM3516, DataFlash, Flash, RAM MIDI test Play sine wave for audio test

* Only implemented in 3516PIAST-C-PDK

5. Synthesizer Tracks mapping table

3516PIA firmware has a built in 32-tracks GM synthesizer. Mapping of the sound tracks is shown in the table below:

Sound Player	Track number (0-31)
Keyboard Single or Upper Sound	0
Keyboard Dual Sound	1
Keyboard Lower Sound	2
Sympathetic Notes for keyboard	3
Sympathetic Notes for demo, MIDI In, sequencer	4
Demo Piano track 1	7
Demo Piano track 2	8
MIDI In Piano track 1	7
MIDI In Piano track 2	8
Sequencer Piano track 1, Single Sound	7
Sequencer Piano track 1, Dual Sound	8
Additional Demo tracks	9-14
Piano Sequencer dual tracks 2-4	9-14
Metronome	15
Style Player	24-31
MIDI File Player	16-31
MIDI IN in GM Mode	16-31
USB MIDI In GM Mode	16-31

6. 3516PIA DSP Modules and Audio Routings

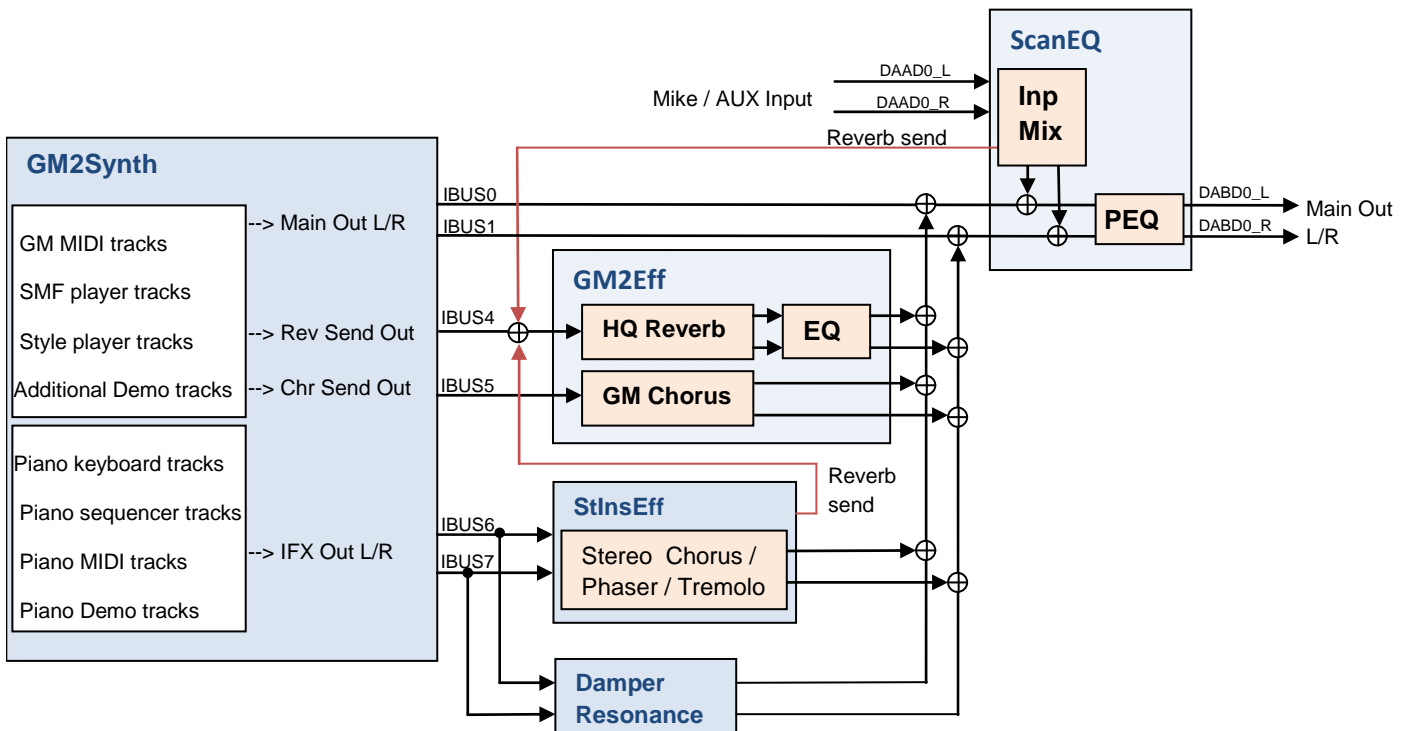

7. MIDI Implementation

7.1. Special Piano Effect NRPN Controls

Midi channel is “don’t care” for all these Nrpn.

NRPN sending method:

CTRL#99=high byte, CTRL#98=low byte, CTRL#6=vv

Example:

NRPN Equalizer High band 3907H = 60H

- CTRL#99=57 (39h) (Midi code: 0B0h 063h 039h)
- CTRL#98=07 (Midi code: 0B0h 062h 007h)
- CTRL#6=96 (60h) (Midi code: 0B0h 006h 060h)

NRPN # (High Low)	Description	Power-up default
Damper Resonance Effect Controls		
0200H	Damper Resonance Level (0..127)	40
0201H	Damper Resonance Response (Fade-In/Out time, 0..15 = 20µs..0.66s)	12=80ms
0202H	Pre-Low-Pass Filter (0=cut freq at ~2KHz, till 127=filter full open)	127
0203H	Pre-High-Pass Filter (0=no filtering, till 127=cut freq at ~1KHz)	10
0204H	Reverberation Time (0..127)	64
0205H	Reverberation Hi-Damp (0..127)	64
0206H	Post-High-Shelf Filter Gain (0=-12dB, 64=0dB, 127=+6dB)	100
0207H	Post-High-Shelf Filter Freq (0..127, ~800Hz to 3KHz)	0
Reverb Effect Controls		
0300H	Reverb Level (0..127)	64
0301H	Pre-Delay Time (0 = 0ms, till 127 = 250ms)	0
0302H	Reverberation Time (0..127)	64
0303H	Pre-Low-Pass Filter (0=filter open, till 7=filter closed)	64
0304H	Post-Low-Shelf Filter Gain (0=-12dB..64=0dB..127=+12dB)	64
0305H	Post-High-Shelf Filter Gain (0=-12dB..64=0dB..127=+12dB)	64
0306H	Delay Feedback Amount (0..127, only for Reverb type 6 and 7)	64
0307H	Reverb Type (1..2=room, 3..4=hall, 5=plate, 6..7=delay)	*
Chorus/Phaser/Tremolo Effect Controls		
0400H	Effect Level	64
0401H	Chorus/Flanging Delay Time (0 = 1ms, till 127 = 10.6ms)	*
0402H	Chorus Feedback (0..127)	*
0403H	Pre-Low-Pass Filter (0..127, 127=no filtering)	127
0407H	Modulation Effect Type: 0=Chorus, 2=Tremolo, 3=Phaser	*
0408H	Modulation Rate: 0 = ~0,023 Hz, ...64=~0,89Hz, till 127 = ~5,8 Hz	*
0409H	Modulation Depth (0..127)	*
040AH	Tremolo Shape (0=triangle, till 127=rectangle, only for Tremolo type)	*
PEQ Controls		
3900h	Equalizer Low Band Gain 0=-12dB, 40h=0dB, 7Fh=+12dB	40h
3901h	Equalizer Low Mid Band Gain 0=-15dB, 40h=0dB, 7Fh=+15dB	40h
3902h	Equalizer High Mid Band Gain 0=-15dB, 40h=0dB, 7Fh=+15dB	40h
3903h	Equalizer High Band Gain 0=-12dB, 40h=0dB, 7Fh=+12dB	40h
3904h	Equalizer Low Band Freq 0=40Hz, 40h=310Hz, 7Fh=620Hz	0Ah=80Hz
3905h	Equalizer Low Mid Band Freq 0=60Hz, 40h=3KHz, 7Fh=6.3kHz	08h=500Hz
3906h	Equalizer High Mid Band Freq 0=60Hz, 40h=6KHz, 7Fh=12.5kHz	53h=8KHz
3907h	Equalizer High Band Freq 0=780Hz, 40h=2.7KHz, 7Fh=4.5kHz	7Fh=4.5KHz
3908h	Equalizer Low Mid Band Q 0:Q=1, 40h:Q=2, 7Fh:Q=20	40h
3909h	Equalizer High Mid Band Q 0:Q=1, 40h:Q=2, 7Fh:Q=20	40h

(To be continued)

(continued)

NRPN # (High Low)	Description	Power-up default
Mike/AUX Input Controls		
3A20h	Mike 1 / AUXL Input Level	7Fh
3A21h	Mike 2 / AUXR Input Level	0
3A22h	CODEC ADC Input Gain 0 = muted, till 127 = +18dB	0
3A24h	Mike1&2 : AUXL&R to FX (Reverb) send	40h
3A28h	Mike1 / AUXL to Left Output level	7Fh
3A29h	Mike1 / AUXL to Right Output level	7Fh
3A2Ah	Mike 2 / AUXR to Left Output level	0
3A2Bh	Mike 2 / AUXR to Right Output level	0

* depending on Effect Preset parameter settings

7.2. Detailed MIDI Implementation

MIDI MESSAGE	HEX CODE	DESCRIPTION
NOTE ON	9nH kk vv	Midi channel n(0-15) note ON #kk(1-127), velocity vv(1-127). vv=0 means NOTE OFF
NOTE OFF	8nH kk vv	Midi channel n(0-15) note OFF #kk(1-127), vv is don't care.
PITCH BEND	EnH bl bh	Pitch bend as specified by bh bl (14 bits) Maximum swing is +/- 1 tone (power-up). Can be changed using "pitch bend sensitivity". Center position is 00H 40H.
PROGRAM CHANGE	CnH pp	Program (patch) change. Specific action on channel 10 (n=9) : select drumset. Refer to sounds / drumset list. Drumsets can be assigned to other channels (see SYSEX MIDI channel to part assign and part to rhythm allocation)
CHANNEL AFTERTOUCH	DnH vv	vv pressure value. Effect set using Sys. Ex. 40H 2nH 20H-26H
MIDI RESET	FFH	Reset to power-up condition
CTRL 00	BnH 00H cc	Bank select: Refer to sounds list. No action on drumset. cc=64 reserved for dream sound editor
CTRL 01	BnH 01H cc	Modulation wheel. Rate and maximum depth can be set using SYSEX
CTRL 05	BnH 05H cc	Portamento time.
CTRL 06	BnH 06H cc	Data entry: provides data to RPN and NRPN
CTRL 07	BnH 07H cc	Volume (default=100)
CTRL 10	BnH 0AH cc	Pan (default=64 center)
CTRL 11	BnH 0BH cc	Expression (default=127)
CTRL 64	BnH 40H cc	Sustain (damper) pedal
CTRL 65	BnH 41H cc	Portamento ON/OFF
CTRL 66	BnH 42H cc	Sostenuto pedal
CTRL 67	BnH 43H cc	Soft pedal
CTRL 84	BnH 54H vv	Portamento control
CTRL 91	BnH 5BH vv	Reverb send level vv=00H to 7FH
CTRL 93	BnH 5DH vv	Chorus send level vv=00H to 7FH
CTRL 98	BnH 62H vv	Nrpn LSB
CTRL 99	BnH 63H vv	Nrpn MSB
CTRL 100	BnH 64H vv	Rpn LSB
CTRL 101	BnH 65H vv	Rpn MSB
CTRL 120	BnH 78H 00H	All sound off (abrupt stop of sound on channel n)
CTRL 121	BnH 79H 00H	Reset all controllers
CTRL 122	BnH 7AH 00H	Local Control on/off
CTRL 123	BnH 7BH 00H	All notes off
CTRL 126	BnH 7EH 00H	Mono on
CTRL 127	BnH 7FH 00H	Poly on (default power-up)

(To be continued)

(continued)

MIDI MESSAGE	HEX CODE	DESCRIPTION
CTRL CC1	BnH ccH vvH	Assignable Controller 1. cc=Controller number (0-5Fh), vv=Control value (0-7Fh). Control number (ccH) can be set on CC1 CONTROLLER NUMBER (Sys. Ex 40 1x 1F). The resulting effect is determined by CC1 controller function (Sys.Ex. 40 2x 40-4A)
CTRL CC2	BnH ccH vvH	Assignable Controller 2. cc=Controller number (00h-5Fh), vv=control value (0-7Fh). Control number can be set on CC2 CONTROLLER NUMBER (Sys.Ex. 40 1x 20). The resulting effect is determined by CC2 controller function (Sys.Ex.40 2x 50-5A).
RPN 0000H	BnH 65H 00H 64H 00H 06H vv	Pitch bend sensitivity in semitones (default=2)
RPN 0001H	BnH 65H 00H 64H 01H 06H vv	Fine tuning in cents (vv=00 -100, vv=40H 0, vv=7FH +100)
RPN 0002H	BnH 65H 00H 64H 02H 06H vv	Coarse tuning in half-tones (vv=00 -64, vv=40H 0, vv=7FH +64)
NRPN 0108H	BnH 63H 01H 62H 08H 06H vv	Vibrate rate modify (vv=40H -> no modif)
NRPN 0109H	BnH 63H 01H 62H 09H 06H vv	Vibrate depth modify (vv=40H -> no modif)
NRPN 010AH	BnH 63H 01H 62H 0AH 06H vv	Vibrate delay modify (vv=40H -> no modif)
NRPN 0120H	BnH 63H 01H 62H 20H 06H vv	TVF cutoff freq modify(vv=40H -> no modif)
NRPN 0121H	BnH 63H 01H 62H 21H 06H vv	TVF resonance modify (vv=40H -> no modif)
NRPN 0163H	BnH 63H 01H 62H 63H 06H vv	Env. attack time modify(vv=40H ->no modif)
NRPN 0164H	BnH 63H 01H 62H 64H 06H vv	Env. decay time modify(vv=40H -> no modif)
NRPN 0166H	BnH 63H 01H 62H 66H 06H vv	Env. release time modif(vv=40H ->no modif)
NRPN 02xxH	BnH 63H 02H 62H xx 06H vv	Special Damper Resonance controls (see § 4.1. above)
NRPN 03xxH	BnH 63H 03H 62H xx 06H vv	Special Reverb controls (see § 4.1. above)
NRPN 04xxH	BnH 63H 04H 62H xx 06H vv	Special Chorus controls (see § 4.1. above)
NRPN 18rrH	BnH 63H 18H 62H rr 06H vv	Pitch coarse of drum instr. note rr in semitones (vv=40H -> no modif) (note 2)
NRPN 1ArrH	BnH 63H 1AH 62H rr 06H vv	Level of drum instrument note rr (vv=00 to 7FH) (note 2)
NRPN 1CrrH	BnH 63H 1CH 62H rr 06H vv	Pan of drum instrument note rr (40H = middle) (note 2)
NRPN 1DrrH	BnH 63H 1DH 62H rr 06H vv	Reverb send level of drum instrument note rr (vv=00 to 7FH) (note 2)
NRPN 1ErrH	BnH 63H 1EH 62H rr 06H vv	Chorus send level of drum instrument note rr (vv=00 to 7FH) (note 2)
NRPN 39xxH	BnH 63H 39H 62H xx 06H vv	Special EQ controls (see § 3.1. above)
NRPN 3AxxH	BnH 63H 3AH 62H xx 06H vv	Special Mike/Aux input controls (see § 4.1. above)
Standard Sysex	F0H 7EH 7FH 09H 01H F7H	General MIDI reset
Standard Sysex	F0H 7FH 7FH 04H 01H 00H 11 F7H	Master volume (11=0 to 127, default 127)
SYSEX	F0H 41H 00H 42H 12H 40H 00H 00H dd dd dd dd xx F7H	Master tune (default dd= 00H 04H 00H 00H) -100.0 to +100.0 cents. Nibblized data should be used (always four bytes). For example, to tune to +100.0 cents, sent data should be 00H 07H 0EH 08H
SYSEX	F0H 41H 00H 42H 12H 40H 00H 04H vv xx F7H	Master volume (default vv=7FH)
SYSEX	F0H 41H 00H 42H 12H 40H 00H 05H vv xx F7H	Master key-shift (default vv=40H, no transpose)
SYSEX	F0H 41H 00H 42H 12H 40H 00H 06H vv xx F7H	Master pan (default vv=40H, center)
SYSEX	F0H 41H 00H 42H 12H 40H 00H 7FH 00H xx F7H	GS reset
SYSEX	F0h 41H 00H 42H 12H 40H 01H 10H vv1 vv2 vv3 vv4 vv5 vv6 vv7 vv8 vv9 vv10 vv11 vv12 vv13 vv14 vv15 vv16 xx F7H	Voice reserve : vv1 to vv10=Part 0 to 9 (default vv=2) vv11 to vv16=Part 11 to 16 (default vv=0)
SYSEX	F0H 41H 00H 42H 12H 40H 01H 30H vv xx F7H	Reverb type (vv=0 to 7), default = 04H 00H : Room1 01H : Room2 02H : Room3 03H : Hall1 04H : Hall2 05H : Plate 06H : Delay 07H : Pan delay
SYSEX	F0H 41H 00H 42H 12H 40H 01H 31H vv xx F7H	Reverb character, default 04H
SYSEX	F0H 41H 00H 42H 12H 40H 01H 32H vv xx F7H	Reverb pre-lpf, 00H to 07H, default 0H
SYSEX	F0H 41H 00H 42H 12H 40H 01H 33H vv xx F7H	Reverb master level, default = 64
SYSEX	F0H 41H 00H 42H 12H 40H 01H 34H vv xx F7H	Reverb time
SYSEX	F0H 41H 00H 42H 12H 40H 01H 35H vv xx F7H	Reverb delay feedback. Only if reverb number=6 or 7 (delays)

(To be continued)

(continued)

MIDI MESSAGE	HEX CODE	DESCRIPTION
SYSEX	F0H 41H 00H 42H 12H 40H 01H 37H vv xx F7H	Reverb pre delay time (vv=0 to 7Fh = 0ms to 127ms). Only if reverb number=0 to 5 (reverbs)
SYSEX	F0H 41H 00H 42H 12H 40H 01H 38H vv xx F7H	Chorus type (vv=0 to 7), default = 02H 00H : Chorus1 01H : Chorus2 02H : Chorus3 03H : Chorus4 04H : Feedback 05H : Flanger 06H : Short delay 07H : FB delay
SYSEX	F0H 41H 00H 42H 12H 40H 01H 39H vv xx F7H	Chorus pre-lpf, 00H to 07H, default = 0
SYSEX	F0H 41H 00H 42H 12H 40H 01H 3AH vv xx F7H	Chorus master level, default = 64
SYSEX	F0H 41H 00H 42H 12H 40H 01H 3BH vv xx F7H	Chorus feedback
SYSEX	F0H 41H 00H 42H 12H 40H 01H 3CH vv xx F7H	Chorus delay
SYSEX	F0H 41H 00H 42H 12H 40H 01H 3DH vv xx F7H	Chorus rate
SYSEX	F0H 41H 00H 42H 12H 40H 01H 3EH vv xx F7H	Chorus depth
SYSEX	F0H 41H 00H 42H 12H 40H 01H 3FH vv xx F7H	Chorus send level to reverb
SYSEX	F0H 41H 00H 42H 12H 40H 1pH 02H nn xx F7H	MIDI channel to part assign, p is part (0 to 15), nn is MIDI channel (0 to 15, 16=OFF). This SYSEX allows to assign several parts to a single MIDI channel or to mute a part. Default assignment : part MIDI channel 0 9 (DRUMS) 1-9 0-8 10-15 10-15
SYSEX	F0H 41H 00H 42H 12H 40H 1pH 15H vv xx F7H	Part to rhythm allocation, p is part (0 to 15), vv is 00 (sound part) or 01 (rhythm part). This SYSEX allows a part to play sound or drumset. There is no limitation of the number of parts playing drumset. Default assignment: part 0 plays drums (default MIDI channel 9) all other parts play sound.
SYSEX	F0H 41H 00H 42H 12H 40H 1pH 40H v1 v2 ... v12 xx F7H	Scale tuning, n is MIDI channel (0 to 15), v1 to v12 are 12 semi-tones tuning values (C, C#, D, ... A#, B), in the range -64 (00H) 0 (40H) +63(7FH) cents. This SYSEX allows non chromatic tuning of the musical scale on a given MIDI channel. Default v1, v2, ... ,v12 = 40H, 40H,...,40H (chromatic tuning). Scale tuning has no effect if the part is assigned to a rhythm channel or if the sound played is not of chromatic type.
SYSEX	F0H 41H 00H 42H 12H 40H 1pH 1AH vv xx F7H	Velocity slope from 00H to 7FH (default = 40H)
SYSEX	F0H 41H 00H 42H 12H 40H 1pH 1BH vv xx F7H	Velocity offset from 00H to 7FH (default = 40H)
SYSEX	F0H 41H 00H 42H 12H 40H 1pH 1FH vv xx F7H	CC1 Controller number (00-5FH) (default = 10H)
SYSEX	F0H 41H 00H 42H 12H 40H 1pH 20H vv xx F7H	CC2 Controller number (00-5FH) (default = 11H)
SYSEX	F0H 41H 00H 42H 12H 40H 2pH 00H vv xx F7H	Mod pitch control (-24,+24 semitone) (default = 40H)
SYSEX	F0H 41H 00H 42H 12H 40H 2pH 01H vv xx F7H	Mod tvf cutoff control (default = 40H)
SYSEX	F0H 41H 00H 42H 12H 40H 2pH 02H vv xx F7H	Mod Amplitude control (-100%+100%) (default=40H)
SYSEX	F0H 41H 00H 42H 12H 40H 2pH 03H vv xx F7H	Mod lfo1 rate control (default = 40H). n is don't care. Rate is common on all channels

(To be continued)

(continued)

MIDI MESSAGE	HEX CODE	DESCRIPTION
SYSEX	F0H 41H 00H 42H 12H 40H 2pH 04H vv xx F7H	Mod lfo1 pitch depth (0-600 cents) (default=0AH)
SYSEX	F0H 41H 00H 42H 12H 40H 2pH 05H vv xx F7H	Mod lfo1 tvf depth (default = 0H)
SYSEX	F0H 41H 00H 42H 12H 40H 2pH 06H vv xx F7H	Mod lfo1 tva depth (0-100%) (default = 0H)
SYSEX	F0H 41H 00H 42H 12H 40H 2pH 10H vv xx F7H	Bend pitch control (-24,+24 semitone) (default = 42H)
SYSEX	F0H 41H 00H 42H 12H 40H 2pH 11H vv xx F7H	Bend tvf cutoff control (default = 40H)
SYSEX	F0H 41H 00H 42H 12H 40H 2pH 12H vv xx F7H	Bend Amplitude control (-100%+100%) (default=40H)
SYSEX	F0H 41H 00H 42H 12H 40H 2pH 14H vv xx F7H	Bend lfo1 pitch depth (0-600 cents) (default=0H)
SYSEX	F0H 41H 00H 42H 12H 40H 2pH 15H vv xx F7H	Bend lfo1 tvf depth (default = 0H)
SYSEX	F0H 41H 00H 42H 12H 40H 2pH 16H vv xx F7H	Bend lfo1 tva depth (0-100%) (default = 0H)
SYSEX	F0H 41H 00H 42H 12H 40H 2pH 20H vv xx F7H	CAF pitch control (-24,+24 semitone) (default = 40H)
SYSEX	F0H 41H 00H 42H 12H 40H 2pH 21H vv xx F7H	CAF tvf cutoff control (default = 40H)
SYSEX	F0H 41H 00H 42H 12H 40H 2pH 22H vv xx F7H	CAF Amplitude control (-100%+100%) (default=40H)
SYSEX	F0H 41H 00H 42H 12H 40H 2pH 24H vv xx F7H	CAF lfo1 pitch depth (0-600 cents) (default=0H)
SYSEX	F0H 41H 00H 42H 12H 40H 2pH 25H vv xx F7H	CAF lfo1 tvf depth (default = 0H)
SYSEX	F0H 41H 00H 42H 12H 40H 2pH 26H vv xx F7H	CAF lfo1 tva depth (0-100%) (default = 0H)
SYSEX	F0H 41H 00H 42H 12H 40H 2pH 40H vv xx F7H	CC1 pitch control (-24,+24 semitone) (default = 40H)
SYSEX	F0H 41H 00H 42H 12H 40H 2pH 41H vv xx F7H	CC1 tvf cutoff control (default = 40H)
SYSEX	F0H 41H 00H 42H 12H 40H 2pH 42H vv xx F7H	CC1 Amplitude control (-100%+100%) (default=40H)
SYSEX	F0H 41H 00H 42H 12H 40H 2pH 44H vv xx F7H	CC1 lfo1 pitch depth (0-600 cents) (default=0H)
SYSEX	F0H 41H 00H 42H 12H 40H 2pH 45H vv xx F7H	CC1 lfo1 tvf depth (default = 0H)
SYSEX	F0H 41H 00H 42H 12H 40H 2pH 46H vv xx F7H	CC1 lfo1 tva depth (0-100%) (default = 0H)
SYSEX	F0H 41H 00H 42H 12H 40H 2pH 50H vv xx F7H	CC2 pitch control (-24,+24 semitone) (default = 40H)
SYSEX	F0H 41H 00H 42H 12H 40H 2pH 51H vv xx F7H	CC2 tvf cutoff control (default = 40H)
SYSEX	F0H 41H 00H 42H 12H 40H 2pH 52H vv xx F7H	CC2 Amplitude control (-100%+100%) (default=40H)
SYSEX	F0H 41H 00H 42H 12H 40H 2pH 54H vv xx F7H	CC2 lfo1 pitch depth (0-600 cents) (default=0H)
SYSEX	F0H 41H 00H 42H 12H 40H 2pH 55H vv xx F7H	CC2 lfo1 tvf depth (default = 0H)
SYSEX	F0H 41H 00H 42H 12H 40H 2pH 56H vv xx F7H	CC2 lfo1 tva depth (0-100%) (default = 0H)

Notes:

1. NRPN sending method: CTRL#99=high byte, CTRL#98=low byte, CTRL#6=vv
 Example: NRPN 0108H = 40H -> CTRL#99=1, CTRL#98=8, CTRL#6=64

x or xx means “ don't care ”

2. Drumset edit Nrpn:

2 different drumset edit tables are implemented:

- 1 for midi channel 10

- 1 for midi channels 1-9 or 11-16: for all these channels, edit table is the same

8. Update Flash content through USB

8.1. Overview

Flash content can be updated through USB interface. See 3516PIA-MAP.pdf for detail on the procedure and on dedicated UXChange tool.

Flash update through USB can be accelerated by starting the 3516PIA-DK board in Accelerated Update mode.

8.2. Starting Accelerated Update mode

While starting-up the 3516PIA-DK board, press highest G and C for 2 seconds. Display shows “ U p d ”. Then, flash update can be started and will be proceeded in Accelerated mode.

To recover normal playing mode, product should be restarted.

9. Production Test

9.1. Overview

Production test is implemented in firmware. It allows easily testing of each manufactured device at the final step of production.

9.2. Starting Production Test

While starting-up the 3516PIA-DK board, press highest F# and C for 2 seconds. Display and LEDs go to off state.

9.3. LEDs and switches test

Switches with one LED (excepted instrument select switches): Press each switch to test it and its LEDs. LED is on when switch is pressed and off when switch is released.

Switches with more than one LED: Press few times the same switch until you have seen each LED on and off.

Switches without LED: Press the switch 8 times and check each time if one segment is on in the display.

- SET switch is for high digit test
- MINUS switch is for medium digit test
- PLUS switch is for low digit test

Instrument select switches: Press switch to test its LED. LED stays on until another instrument switch is pressed.

9.4. Sliders test

Slider 1: Press Instrument 1 switch. Instrument 1 LED is on. Move slider 1 from left to right. Display shows values increasing regularly from 0 to 127

Slider 2: Press Instrument 2 switch. Instrument 2 LED is on. Move slider 2 from left to right. Display shows values increasing regularly from 0 to 127

9.5. Pedal test

Soft pedal (left): Press Instrument 3 switch. Instrument 3 LED is on. Press pedal. If pedal is simple switch, display shows 0 when pedal is released and 127 when pedal is depressed. If pedal is analog system, display will show 4 values: 0 then 64 then 80 then 127.

Sostenuto pedal (middle): Press Instrument 4 switch. Instrument 4 LED is on. Display shows 0 when pedal is released and 127 when pedal is depressed.

Damper pedal (right): Press Instrument 5 switch. Instrument 5 LED is on. Press pedal. If pedal is simple switch, display shows 1 when pedal is released and 127 when pedal is depressed. If pedal is analog system, display will show 4 values: 1 then 78 then 90 then 110.

9.6. MIDI test

The purpose of this test is to validate MIDI IN path, MIDI IN socket and MIDI OUT path, MIDI OUT socket.

- Connect MIDI IN to MIDI OUT with MIDI cable.
- Press Instrument 6 switch. Instrument 6 LED is on
- Display shows "M I d" if test passes or "b A d" if test fails.

9.7. Components test

Components test will automatically and consecutively test DataFlash device, 128kx16 effect RAM device, each of the parallel ROM or Flash devices and Firmware integrity. Low part of firmware is located in SAM3516 internal flash and high part is in first page of external ROM or Flash.

To start component test press and hold MINUS switch then also press PLUS switch.

Firmware enters in component test and display shows:

- "dFI" while DataFlash is under test
- "rAM" while 128kx16 effect RAM is under test
- "rOM" while ROM or Flash devices are under test
- "Fir" while Firmware integrity is under test

When test is ended, state of the 5 first Intrument LEDs shows the test result. If the 5 LEDs are on then all components test were successfully passed.

- If Inst 1 LED is off then DataFlash test was fail
- If Inst 2 LED is off then RAM test was failed
- If Inst 3 LED is off then first ROM or Flash device test was fail
- If Inst 4 LED is off then second ROM or Flash device test was fail
- If Inst 5 LED is off then Firmware test was failed

Warning: ROM test can be passed with success only if binary files for ROM or FLASH devices have been created with Dream "MakeROM.exe" tool.

9.8. SAM3516 test

SAM3516 test will test internal chip elements.

To start component test press and hold MINUS switch then also press PLUS switch.

Steps are:

- 1- Test all P24 2kx24 RAM
- 2- Test router memory
- 3- Test all P24 working and start sine wave at 1.5kHz frequency
- 4- Test all P24 1kx24 ROM
- 5- Change sine wave frequency to 1.25kHz
- 6- Test 16Kx24 embedded RAM
- 7- Test 256x16 P16 IRAM
- 8- Change sine wave frequency to 750Hz

If test is success then a full scale, 750Hz, sine wave signal will be generated on main audio L and R output. It could be useful for checking analog output stage of the product

Warning: Firmware stays in an endless loop at the end of the test. To recover normal playing mode, product should be restarted.

Dream Contact

info@dream.fr

Website

<http://www.dream.fr>

This publication neither states nor implies any warranty of any kind, including, but not limited to, implied warrants of merchantability or fitness for a particular application. Dream assumes no responsibility for the use of any circuitry. No circuit patent licenses are implied. The information in this publication is believed to be accurate in all respects at the time of publication but is subject to change without notice. Dream assumes no responsibility for errors and omissions, and disclaims responsibility for any consequences resulting from the information included herein.

© Copyright 2008-2011 Dream S.A.S. France